

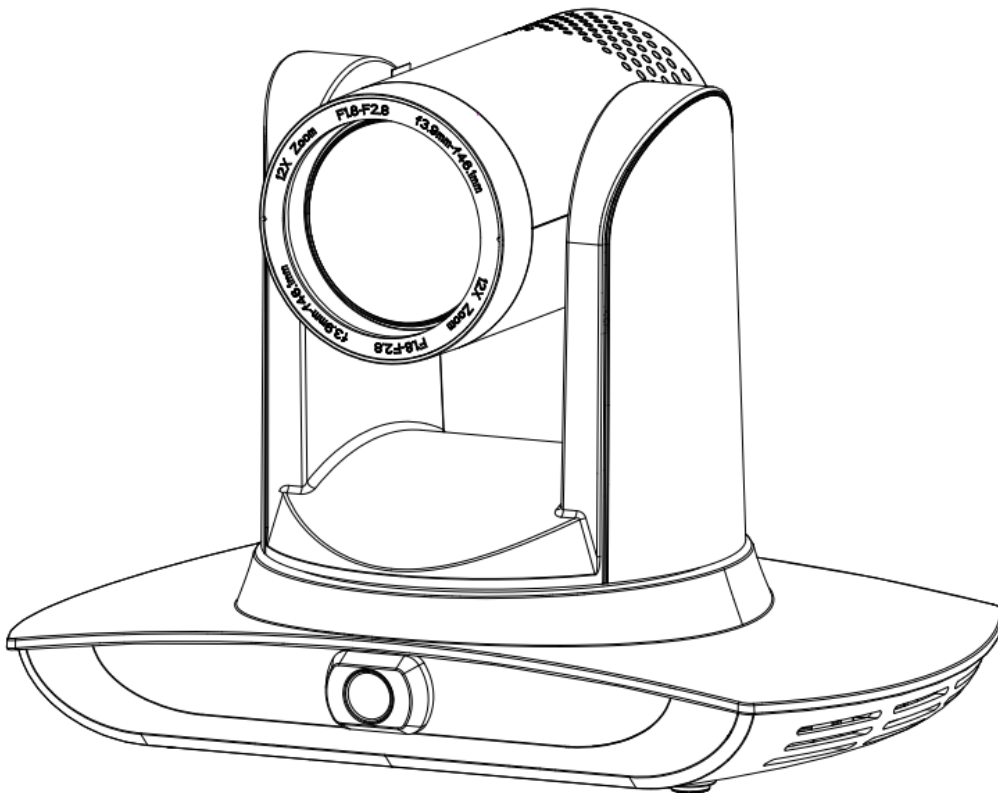

# Auto Tracking PTZ Camera

## WT9700T User Manual



# Precautions

**This manual details functions, installation, operation principles and methods of teacher tracking camera. Please read this manual carefully before installation and use.**

## 1. How to use

In order to prevent this product or products connected to it from being damaged, please use it within its prescribed scope of use.

- 1) Keep the device from rain or moisture;
- 2) To prevent electric shock, do not open the main case; only qualified technicians are allowed to install or maintain the device;
- 3) Do not use the device beyond scope of its temperature, humidity or power supply specification;
- 4) When cleaning the camera lens, swipe it with dry soft cloth. If dirt is hard to be removed, please swipe clean gently with mild detergent. Do not use strong or corrosive detergent, for it may scratch the lens and thus affect image result;

## 2. Electrical safety

Installation and use of this product shall be in strict accordance with safety standards for electricity.

## 3. Careful handing

Avoid damage to product caused by heavy pressure, strong vibration or immersion during transportation, storage and installation.

## 4. Power supply polarity

This product applies DC 12V power supply. Power plug polarity is shown as follows:

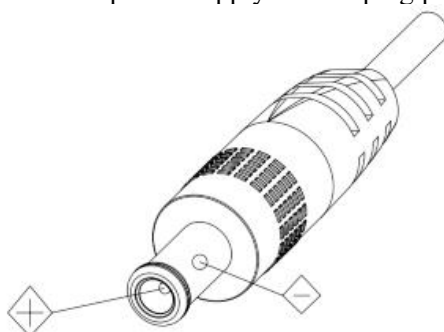

## 5. Install with caution

- 1) Do not rotate the camera head violently, otherwise it may cause mechanical malfunction;
- 2) This product should be placed on a stable desktop or other horizontal surfaces. Do not install the product obliquely, otherwise it may display inclined image;
- 3) When installing the camera on TV or personal computer, use four double faced adhesive pads at the bottom for fixing;
- 4) This product shell is made of organic materials. Do not expose it to any liquid, gas or solids which may corrode the shell.
- 5) During installation, ensure that there are no obstacles within rotation range of the holder;
- 6) Do not power on before finishing installation;

## 6. Do not dismantle the product without permission

This product contains no parts which can be maintained by users. Any damage arising from dismantling the product by user without permission will not be included in warranty.

## 7. Magnetic field interference

Magnetic field under specific frequency may affect this product image; this is Class A product. Application in domestic environment may cause radio interference. Therefore, user should take corresponding measures.



注意

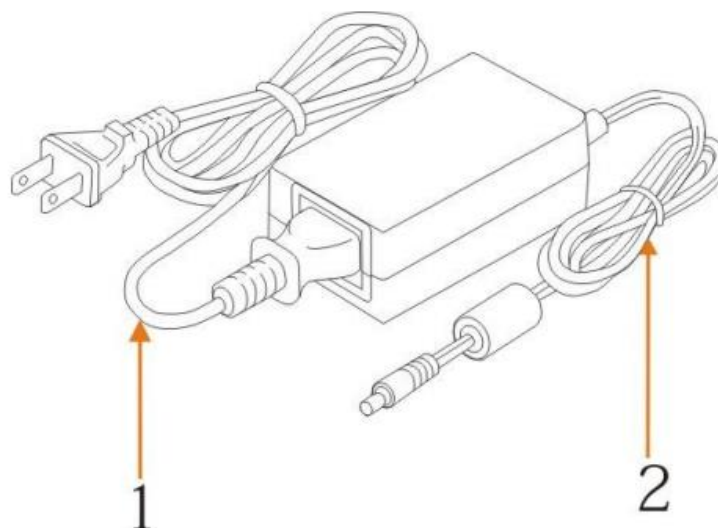

**If it is needed to extend power line of the camera, extend it from terminal 1 (220V/110V) rather than terminal 2 (DC12V), otherwise it will prevent the device from functioning!**

## Table of Contents

Precautions .....	2
1 System overview.....	5
1.1 System introduction.....	5
1.2 Product advantages.....	5
1.3 Product features.....	6
2 Port introduction .....	6
3 Dimensions .....	9
4 System connection .....	10
4.1 Installation layout.....	10
4.2 System wiring.....	11
5 Configuration tools.....	12
5.1 Set IP address of the tracking machine.....	12
5.2 Configure tracking parameters.....	12
5.3 Network update.....	18
6 Description of recording and broadcasting host .....	19
6.1 Auto tracking control .....	19
6.2 Action code docking.....	20
7 Description of remote control .....	22
7.1. Description of keys.....	22
7.2 Use remote control .....	23
8 Set menu.....	24
8. 1 Main menu .....	24
8.2 System parameter settings .....	25
8. 3 Camera parameter settings.....	25
8. 4 P/T/Z.....	28
8. 5 VIDEO FORMAT.....	29
8. 6 Version.....	29
8. 7 Restore default.....	29
9 Technical parameters .....	30
10 VISCA protocol command list.....	31
11Pelco-D protocol command list .....	38
12 Pelco-P protocol command list.....	39
13 Maintenance and troubleshooting .....	40
13.1 Maintenance.....	40
13.2 Troubleshooting.....	40
Copyright statement .....	41

# 1 System overview

## 1.1 System introduction

**Teaching tracking camera system solution** is a dedicated smart camera solution leading in international education information industry.

**Teaching tracking camera products** feature built-in high speed processor and advanced image processing and analytical algorithm, which allows it to track and detect teachers, students and blackboard-writing accurately and quickly. It fully satisfies all scenario demand by recorded broadcasting of teaching and remote interactive teaching.

**Teaching tracking camera products** adopt advanced ISP processing technique and algorithm, producing vivid images which feature balanced brightness, distinct layering, high definition and color reducibility.

**Teaching tracking camera products** are characterized by improved function, high performance, reliable operation, simple use and easy maintenance.

## 1.2 Product advantages

- **Full-scene solution:** Different product combinations satisfy different scenario demands;
- **Networked control interface:** Control information of all products will be transmitted via network, and it is suitable for product layout for all scenarios;
- **Recognition algorithm unrelated to location:** Status detection and recognition of teachers and students adopt unique smart partitioning algorithm to ensure that the result of detection and recognition is unrelated to location;
- **Free installation:** It supports both front installation and upside down installation;
- **It supports 5G WiFi transmission mode**
- **All-in-one design:** The built-in panoramic lens allow perfect combination of panoramic lens and tracking camera;
- **Sophisticated tracking algorithm:** It applies sophisticated human detection, locking and tracking image processing and analytical algorithm (smart image recognition library, scene adaptive algorithm) and achieves stable, fast and accurate target tracking;
- **High immunity from interference:** More diversified and flexible recognition shield settings ensure that once tracking target is locked, it will not be affected by other moving object or projector;
- **Stable tracking:** Movement sensitivity is adjustable. When tracking slight movement of target or hand movement, it will not cause wrong operation of the camera;
- **Self-adaptive image:** The tracking camera zooms depending on distance to target so that the visual image maintains proper size and scale;
- **High environmental suitability:** Tracking result will not be affected by classroom size, shape or seat arrangement;
- **Super wide dynamic exposure:** It solves the issue that tracking object dims in strong light such as projector.

## 1.3 Product features

- **Full HD image:** With 1/2.8 inch high quality image sensor, its maximum resolution ratio reaches 1920x1080;
- **Multiple optical zoom lens:** 12X and 20X optical zoom lens are available. The lens features 72.5° distortionless wide viewing angle;
- **Advanced focusing technique:** The advanced automatic focusing algorithm allows automatic focusing be done quickly, accurately and steadily;
- **Low noise high signal to noise ratio:** Low noise CMOS ensures super high signal to noise ratio of video taken by the camera. With advanced 2D and 3D noise reduction technology, noise is reduced and image resolution is guaranteed.
- **Audio input port:** It supports 16000, 32000, 44100, 48000 sampling frequency and AAC, MP3 and G.711A audio coding;
- **Super quiet holder:** High precision stepping motor and precision motor driven controller ensure the holder operate at low and stable speed without noise;
- **Multiple video compression standards:** It supports H.265/H.264 video compression;
- **Multiple networking protocol:** It supports ONVIF, GB/T28181, RTSP, RTMP protocol and RTMP push mode;
- **Sleep mode:** It supports low-power consumption sleep/wake up mode. Power consumption in sleep mode is lower than 400mW;
- **Multiple control protocol:** It supports VISCA, PELCO-D, PELCO-P protocol, automatic recognition protocol and all command VISCA control protocol;

## 2 Port introduction

### Front view

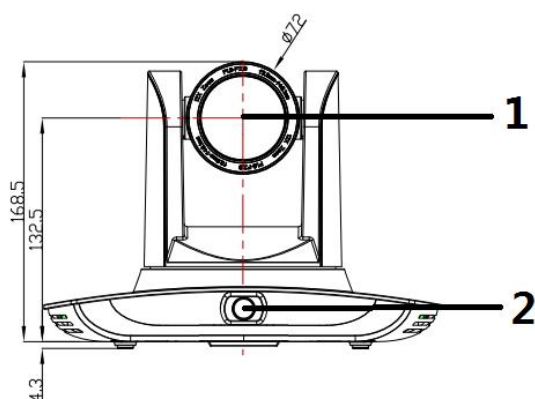

### Rear view

SDI model:

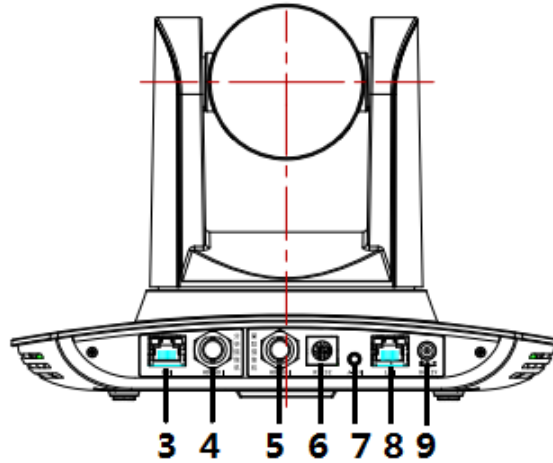

1. Close-up lens
2. Panorama lens
3. LAN network port for panorama lens
4. SDI output 1 (panorama lens output)
5. SDI output 2 (close-up lens output)
6. RS-232 control port
7. Audio input port
8. LAN network port for close-up lens
9. Power supply port (DC12V)

**HDMI U3 Model:**

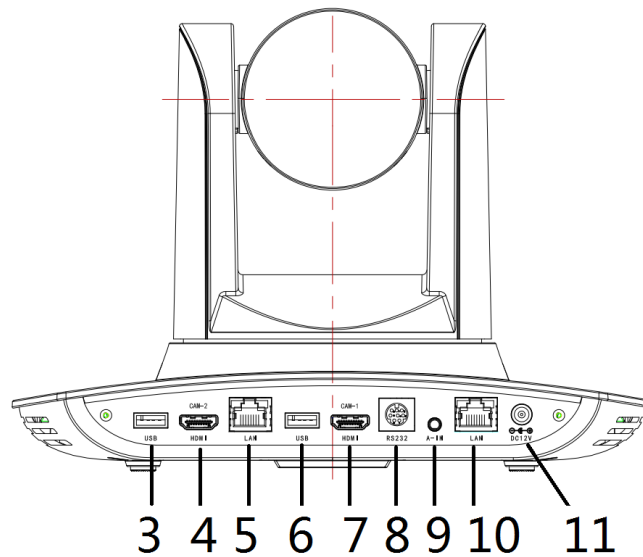

- 1、 Close-up lens
- 2、 Panorama lens
- 3、 USB3.0 output 1 (panorama lens output)
- 4、 HDMIoutput 1 (panorama lens output)
- 5、 LAN network port for panorama lens
- 6、 USB3.0 output 2 (close-up lens output)
- 7、 HDMIoutput 2 (close-up lens output)
- 8、 RS-232 control port
- 9、 Audio input port
- 10、 LAN network port for close-up lens
- 11、 Power supply port (DC12V)

Pin definition:

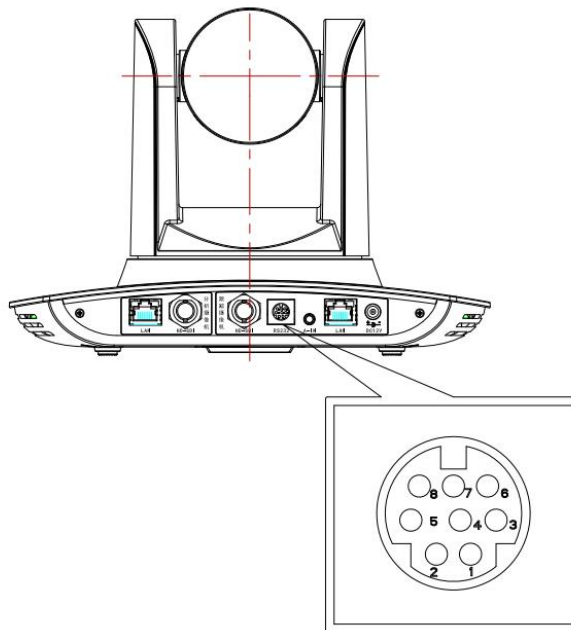

No.	Port	Definition
1	DTR	Data Terminal Ready
2	DSR	Data Set Ready
3	TXD	Transmit Data
4	GND	Signal ground
5	RXD	Receive Data
6	GND	Signal ground
7	IR OUT	IR Commander Signal IR
8	NC	No Connection



# 3 Dimensions

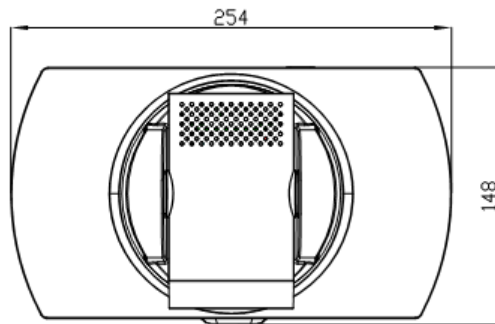
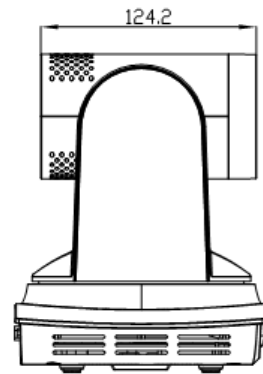
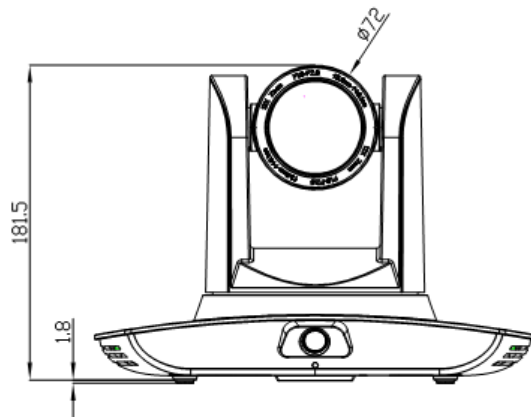
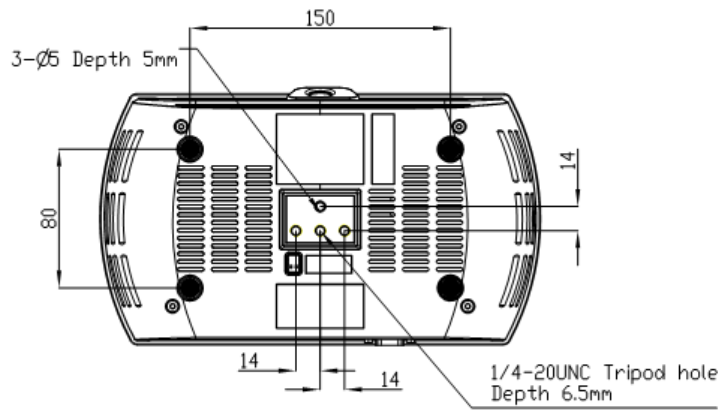

# 4 System connection

## 4.1 Installation layout

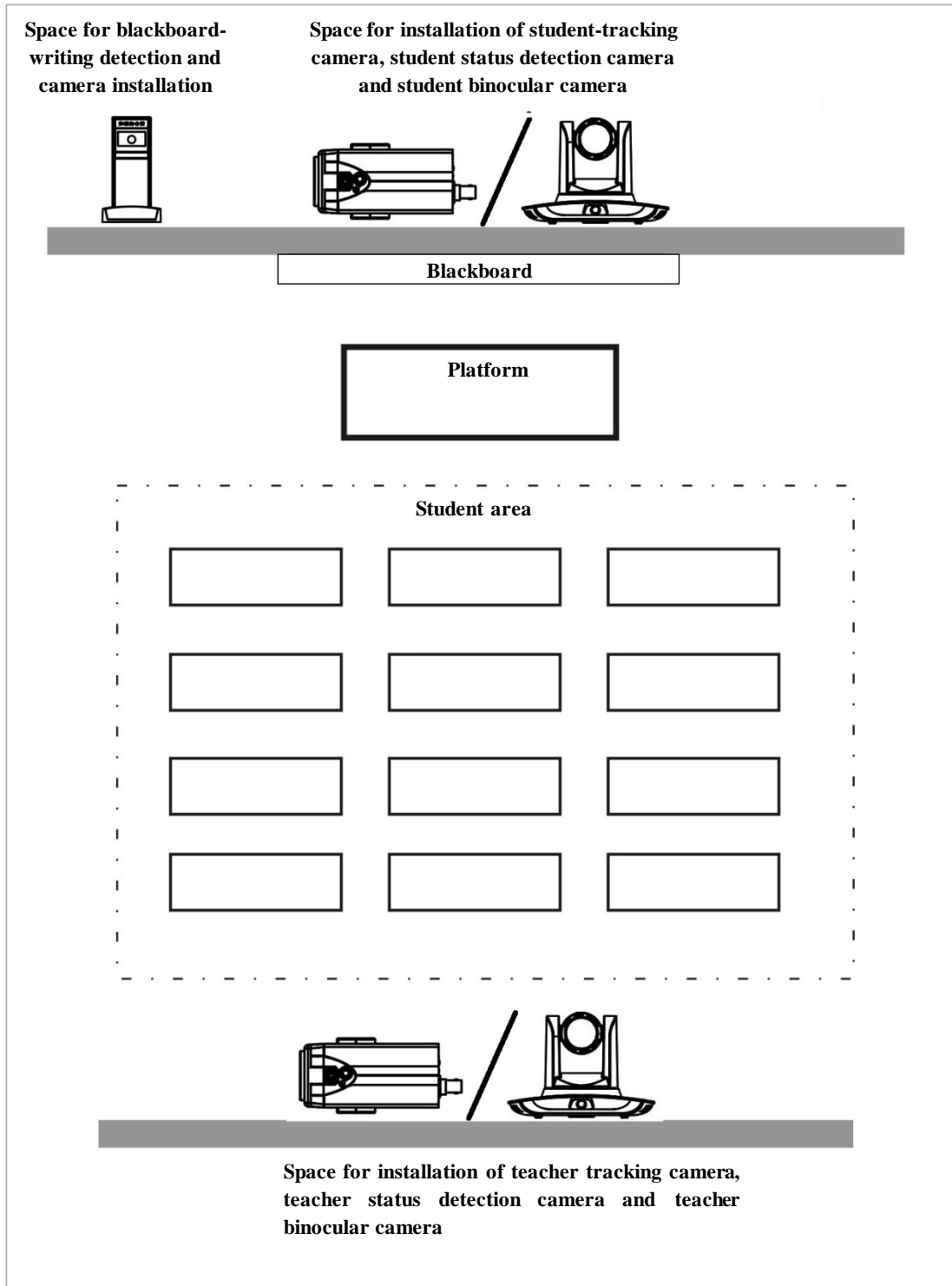

Teacher tracking camera is installed at place 1.8-2.5m from ground (distance from panoramic lens to ground), 5-15m from blackboard (when the distance is 5-9m, 4mm panoramic lens is recommended; when distance is 9-15m, 6mm panoramic lens is recommended). Teacher tracking camera should be installed near central axis of the classroom as much as possible to get the best result of tracking camera shooting.

## 4.2 System wiring

The teaching tracking camera products provide a smart camera solution for education information field, and customers can select all or some products as needed. Different combinations of products meet demand of customers' application scenarios.

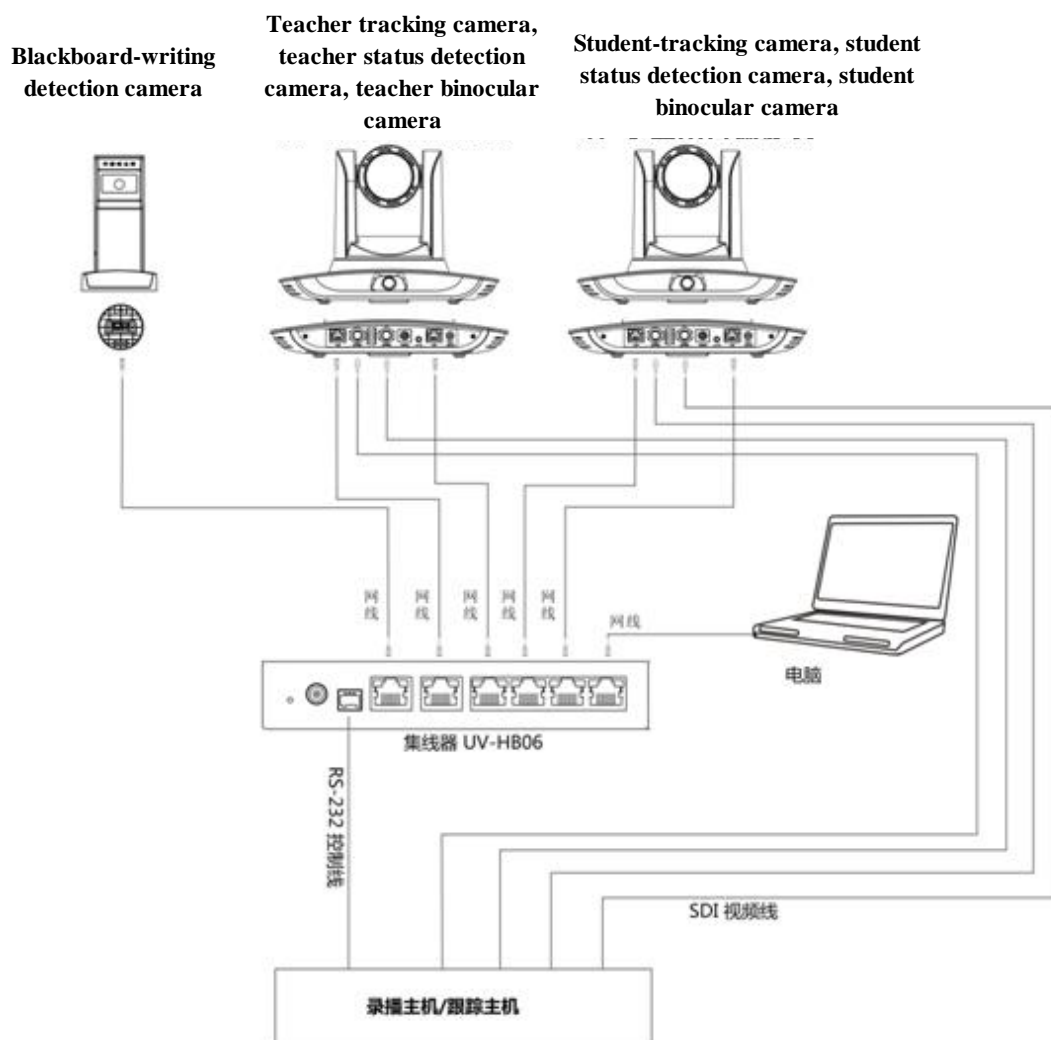

If the recording and broadcasting host supports LAN network control port, the concentrator can be replaced by LAN network switch.

# 5 Configuration tools

## 5.1 Set IP address of the tracking machine

Open IVESmart configuration tool, click Settings -> IP address -> Search successively (refer to Figure 5.1-1 for details), the configuration interface will display all valid devices in the LAN, check type of device to be configured and click Confirm. *Note: Computer for operating IVESmart tool should be in the same LAN with camera configured.*

Device Type	Panoramic IP	Panoramic Port	Panoramic V...	Close-up IP	Close-up Port	Close-up VI...
<input type="checkbox"/> Student Tracking	192.168.5.105	3000	1259	192.168.5.193	3000	1259
<input type="checkbox"/> Hub	192.168.5.190	3000	3001		0	0
<input type="checkbox"/> Hub	192.168.5.190	3000	3001		0	0
<input type="checkbox"/> Hub	192.168.5.190	3000	3001		0	0
<input type="checkbox"/> Teacher Tracking	192.168.5.103	3000	3001	192.168.5.102	3000	1259
<input type="checkbox"/> Teacher Tracking	192.168.4.108	3000	1259	192.168.4.107	3000	1259
<input type="checkbox"/> Teacher Tracking	192.168.4.103	3000	3001	192.168.4.102	3000	1259

Figure 5.1-1 Operation interface

## 5.2 Configure tracking parameters

Set the process

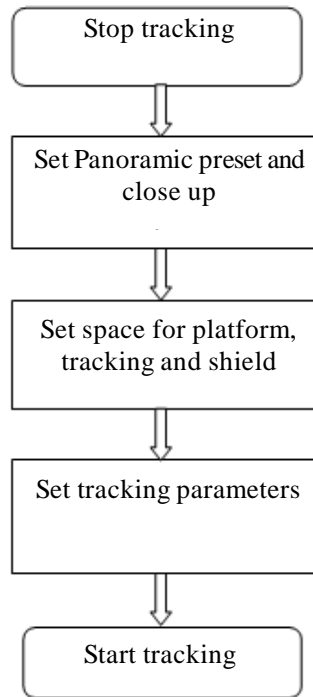

Here, the following is a description of settings according to the process. The main interface of configuration tool is shown in Figure 5.2-1.

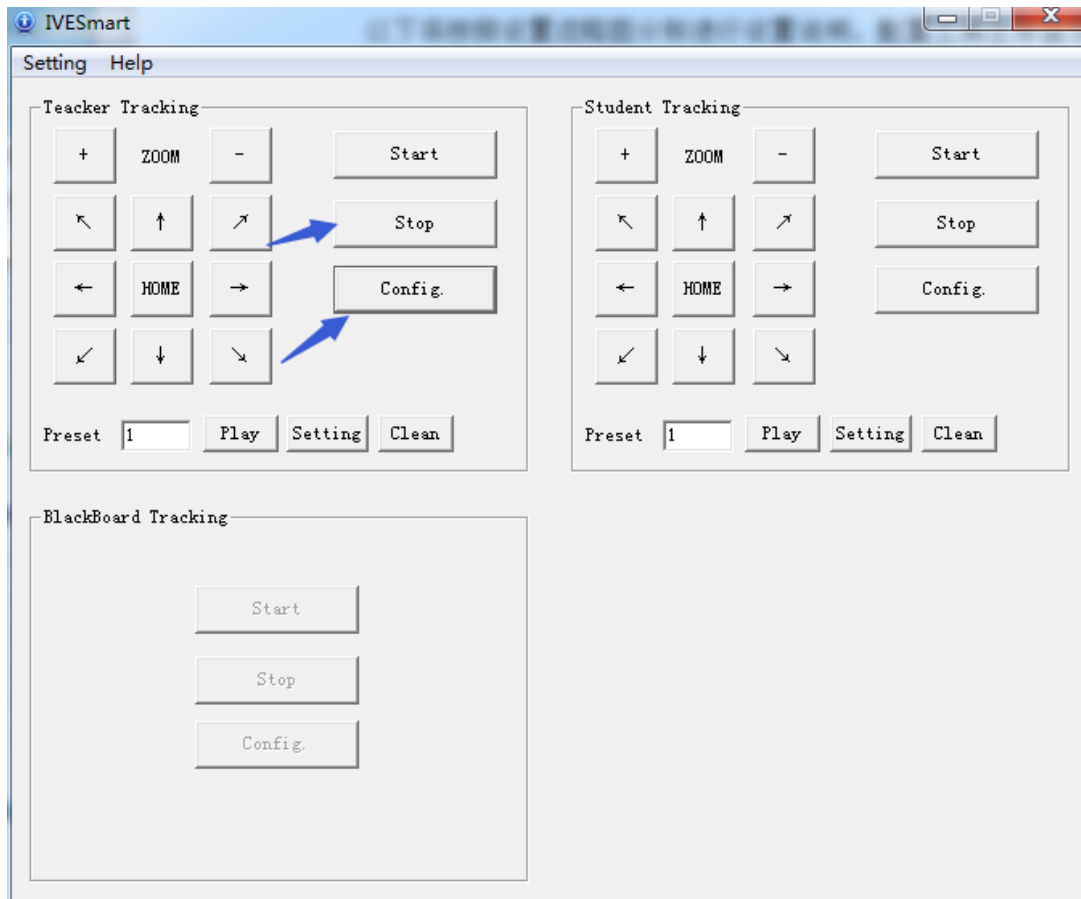

Figure 5.2-1 Operation interface

## 1. Set preset position for close up

Operation interface of setting preset position for close up is shown in Figure 5.2-2. Box indicated by arrow has a holder control button. By controlling holder position and zoom value, it will adjust camera angle and position to preset position and save. Settings of panoramic preset position and platform preset position are as follows:

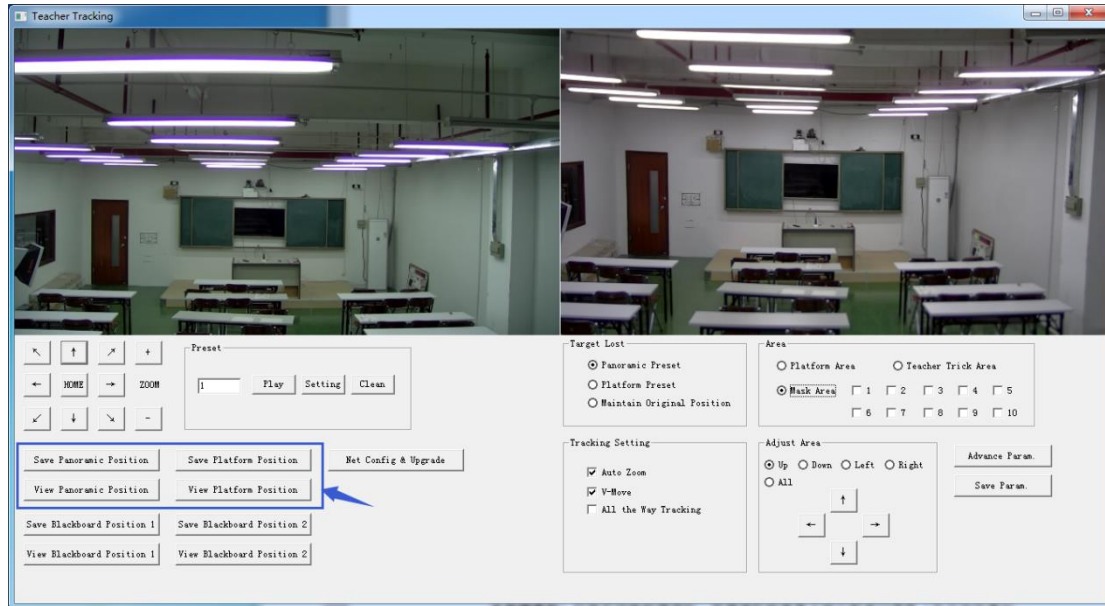

Figure 5.2-2 Operation interface

**Platform preset:** Control teacher tracking camera to make platform (we suggest that teachers stand in the middle of platform, if any) get desired visual result in camera image, then click and save Platform preset. During normal tracking, size of teacher's image in the picture uses Platform preset as a reference. When tracking target disappears, it can select close-up lens to go back to Platform preset.

**Panoramic preset:** Control teacher tracking camera to allow camera to have almost a panoramic of the classroom (or any position). When tracking target disappears, it can select close-up lens to go back to panoramic position.

**Preset for blackboard-writing:** Refer to user manual for blackboard-writing for details.

## 2. Set panoramic lens area

**Platform area:** It is the area tracked once close-up lens start up tracking. It is blackboard area on platform generally so as to ensure that when teacher is on platform his upper body is displayed within setting area, and it will not exceed lower margin of platform area when students in the first row sit down. See Figure 5.2-3.

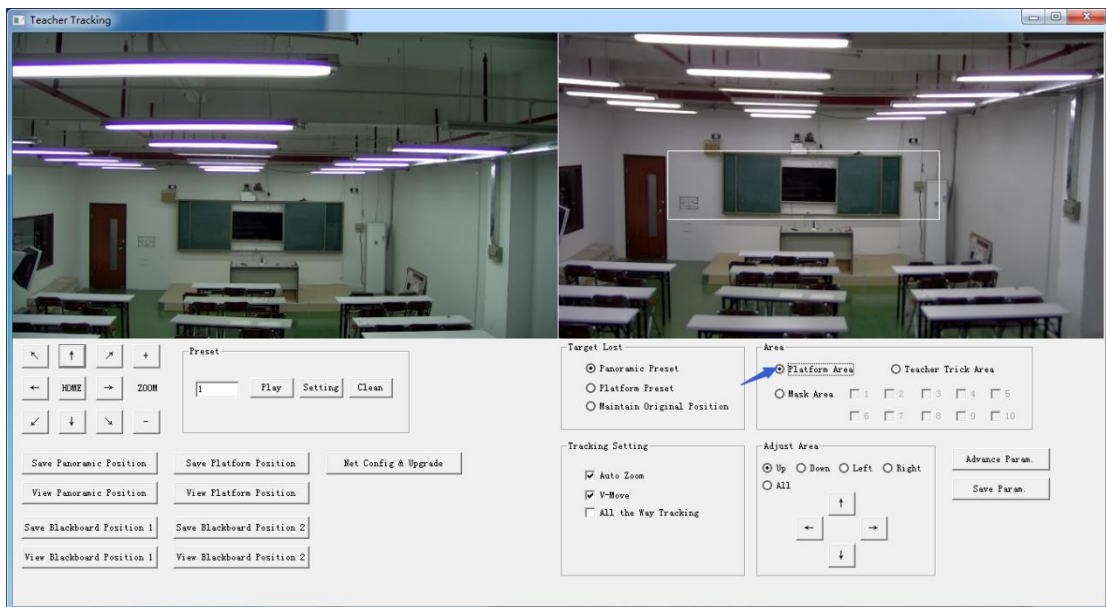

Figure 5.2-3 Operation interface

**Tracking area:** Tracking area means scope of tracking teacher. When the tracking target goes out of the tracking area, it will be considered tracking target losing. The tracking area can be set into polygon according to certain environment conditions, or set student area outside of tracking area. See Figure 5.2-4:

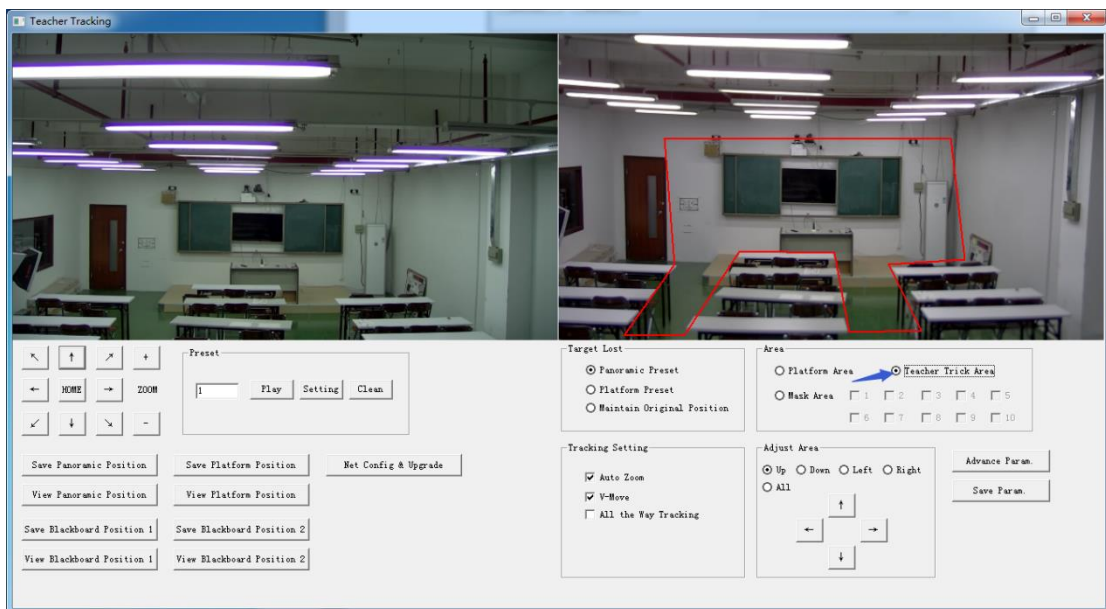

Figure 5.2-4 Operation interface

**Mask area:** Mask area is usually the area which may impact result of teacher tracking, such as places which may have dynamic changes such as TV, projector, doors and windows. See Figure 5.2-5:

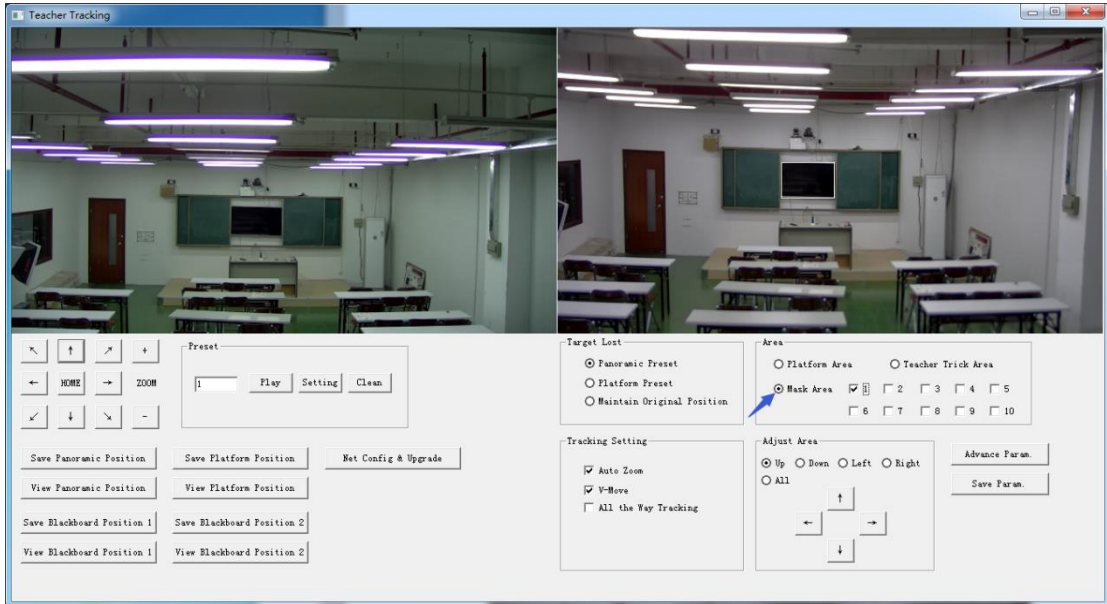

Figure 5.2-5 Operation interface

### 3. Set tracking parameters

**Target lost:** when target loses, the close-up lens will return to designated preset position. This preset position can be panoramic preset, platform preset or maintain original position.

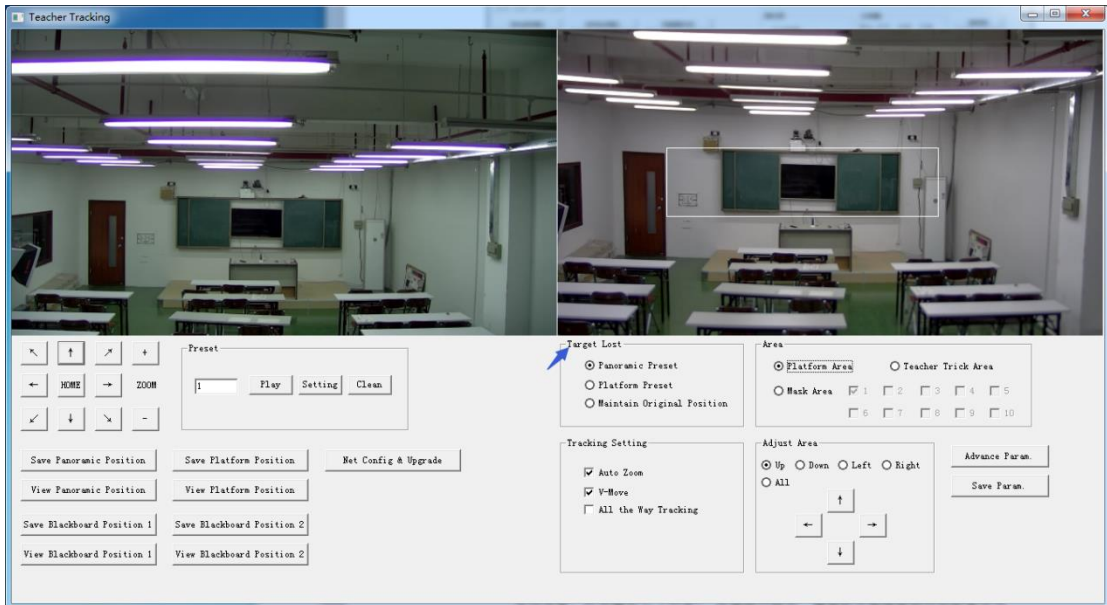

Figure 5.2-6 Operation interface

### Tracking settings:

**Auto zoom:** In open mode (checked), during tracking, the camera will zoom automatically according to target distance; in off mode (unchecked), during teacher tracking, zoom remains the value set during platform preset.

**V-move:** In open mode (checked) and during teacher tracking, the camera will adjust its angle of elevation according to height of tracking target; in off mode (unchecked) and during teacher



tracking, angle of elevation remains the value set during platform preset. If a teacher will not step down platform in class, we suggest turning off auto zoom and v-move.

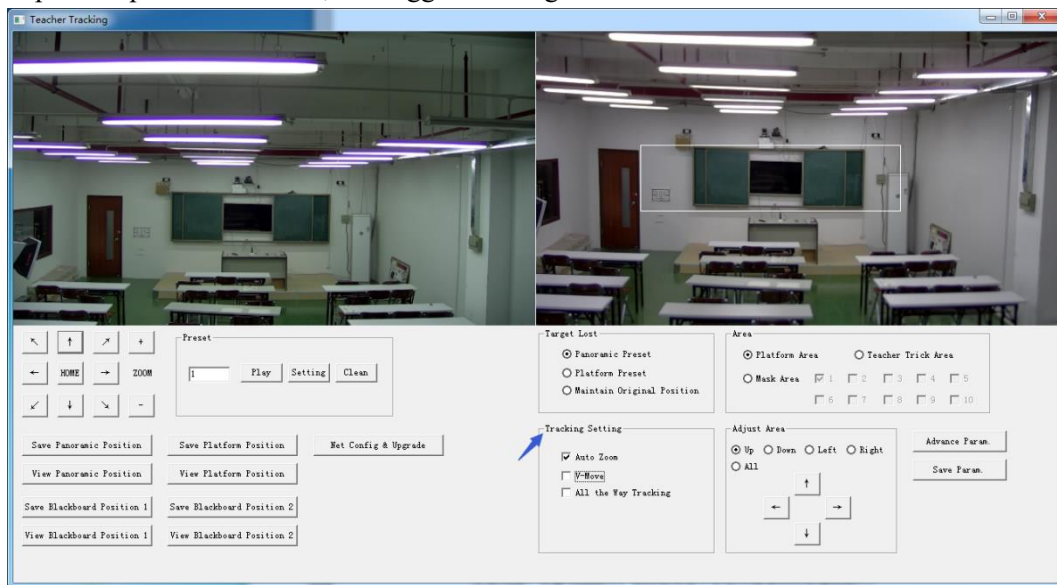

Figure 5.2-7 Operation interface

### Advance parameters:

**Action sensitivity:** In teacher tracking mode, it is the action range required to trigger tracking camera when the tracking target changes from stationary state to motion state. The higher the action sensitivity, the smaller movement of tracking target that will trigger camera's tracking motion.

**H-speed:** It means speed of tracking camera for horizontal tracking.

**V-speed:** It means speed of tracking camera for vertical tracking.

**Zoom range:** The bigger the range, the higher zoom extent required for camera when tracking target steps down platform.

**Lost timeout:** It means time required (5s by default) for tracking camera to perform target lost action when target is lost (optional: return to panorama preset, platform preset, or remain original position).

**Down platform sensitivity:** It is used for determining if teacher steps down platform. The lower the sensitivity, the longer teacher's distance to blackboard it required to trigger teacher down platform action.

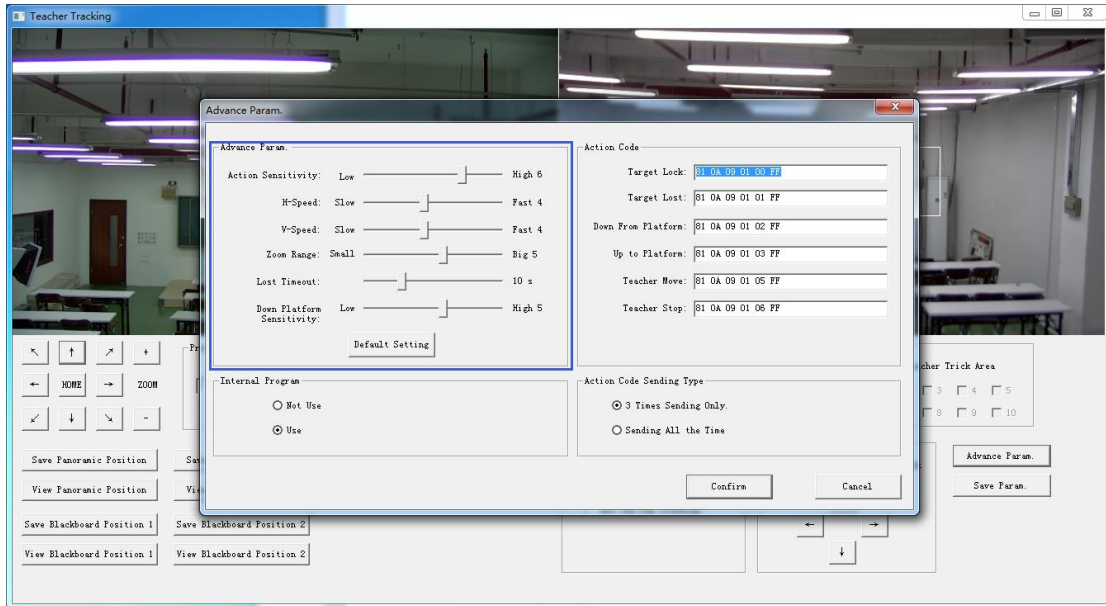

Figure 5.2-5 Operation interface

For settings of action code, refer to “7 Description of connecting recording and broadcasting host”. After setting, click Save Parameter. It allows to entering advance parameter settings column to change configuration value to obtain the best result subject to specific scenes and customer demand.

### 5.3 Network update

When updating the version, it needs to update device via IVESmart configuration tools. Click Configuration -> Network configuration & update to enter update interface, as shown below:

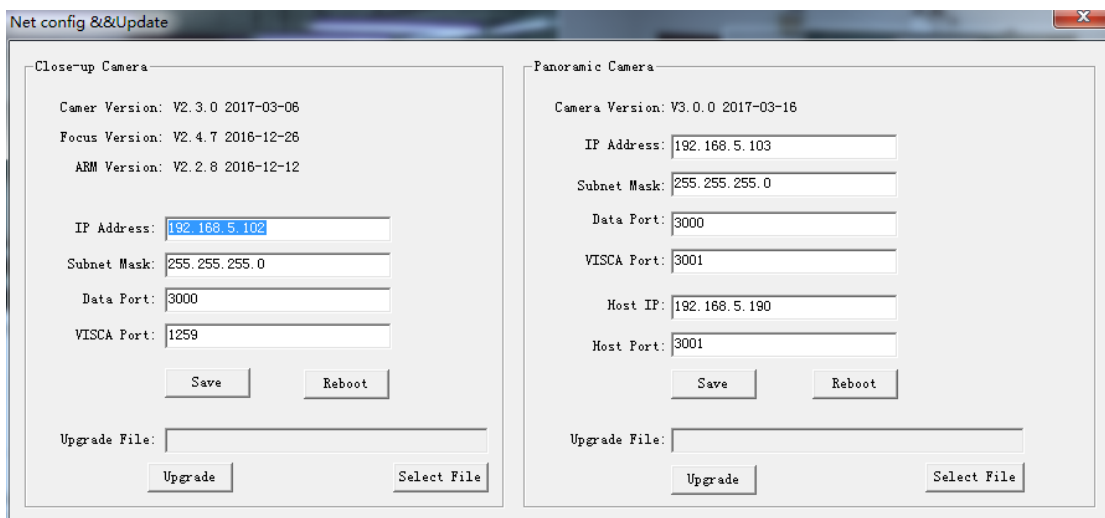
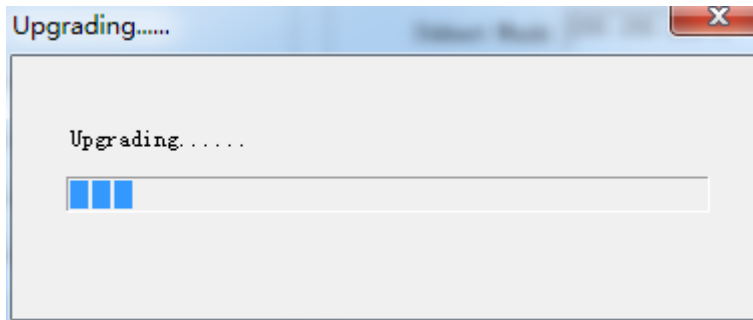

Figure 5.2-8 Operation interface

When upgrading, note whether camera to be upgraded is close-up camera or panorama camera, then click Select file -> upgrade, the following interface appears:



After upgrading is completed, the camera will perform self-inspection.

Note: After grading, you can restore factory settings by combination key [\*] [#] [6] on remote control or by remote control menu.

## 6 Description of recording and broadcasting host

### 6.1 Auto tracking control

The recording and broadcasting host sends command by LAN network port or concentrator RS232 serial port and controls automatic tracking motion of teacher tracking camera. In auto tracking mode, it does not allow control camera holder rotation or zoom by IVESmart configuration tool or remote control; in stop auto tracking mode, it allows control camera holder rotation or zoom by IVESmart configuration tool or remote control.

#### 1. Network receiving address

Address for teacher tracking camera to receive command can be searched in IVESmart configuration tool, click Setting -> IP address -> search successively, as follows:

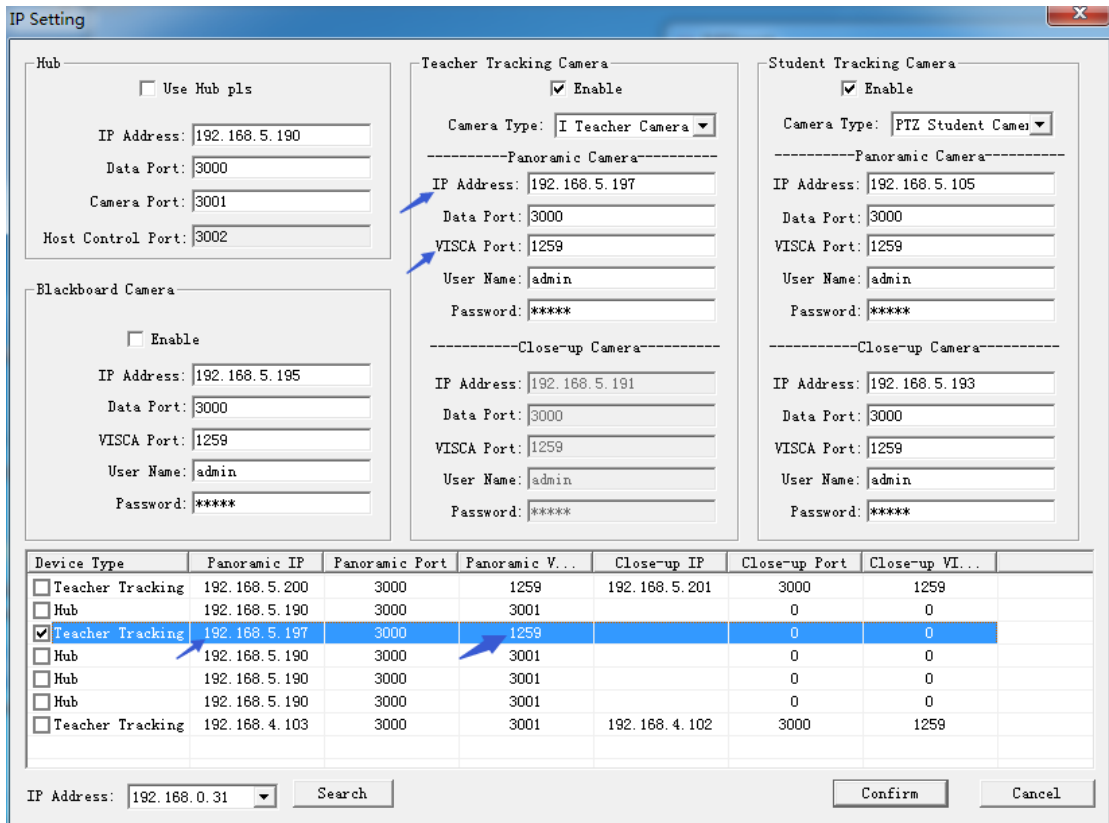

Figure 6.1-1 Operation interface

## 2. Command

Type	Command
Start teacher tracking	0x810x0A 0x08 0x01 0x020xFF
Stop teacher tracking	0x81 0x0A 0x08 0x01 0x03 0xFF

## 6.2 Action code docking

Tracking status of teacher tracking camera will be feed back to recording and broadcasting host via network (UDP transmission mode) or concentrator (RS232 serial port) in the form of action code.

### 1. Configure recording and broadcasting host address

If recording and broadcasting host uses LAN to receive action code, then it needs to configure host address by IVESmart configuration tool. Click **Configuration -> Network configuration & update**, as shown below:

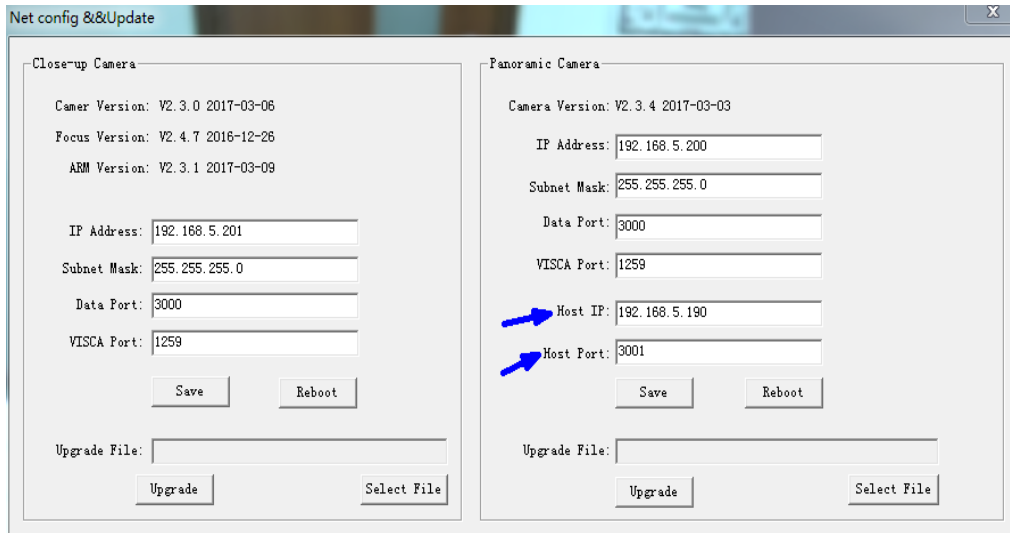

Figure 6.2-1 Operation interface

## 2. Configure action code

Edit action code as needed via IVESmart configuration tool. Click Configuration -> advance parameters successively;

After modification, click Confirm -> save parameters, as shown below:

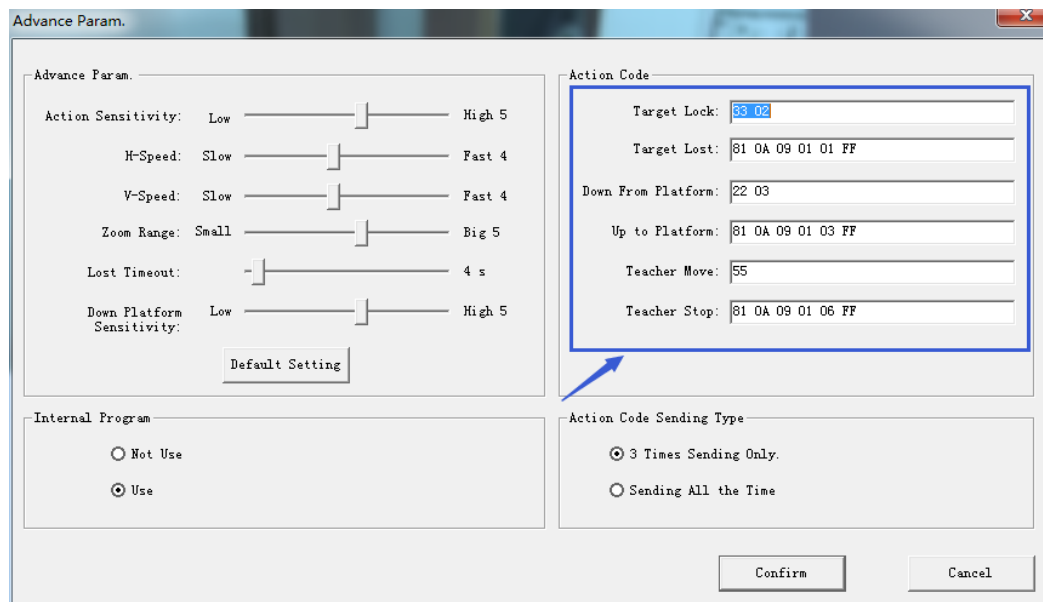

Figure 6.2-2 Operation interface

# 7 Description of remote control

## 7.1. Description of keys



### 1. Standby key

Long press standby key for 3s, camera enters standby mode, long press this key again for 3s, camera will perform self-inspection again and return to HOME position. When setting #0 as preset, when there is no action within 12s, the holder will return to #0 preset.

### 2. Select camera

Select address number of camera to be controlled.

### 3. Number key

Set or call #0-9 preset.

### 4. \*key and #key

### 5. Focusing control key: adjust focusing.

[Auto focusing]: Enter auto focusing mode

[Manual focusing]: shift camera focusing mode to manual; adjust focusing via [Focusing +] or [Focusing -]

### 6. Zoom key

[Zoom] +: zoom out lens; [Zoom -]: zoom in lens

### 7. Set and clear preset key

**Set preset: Save a preset**, set preset + number key (0-9), that is set preset of corresponding number key;

**Cancel preset: Cancel a preset**, cancel preset + number key (0-9), that is cancel preset of corresponding number key;

### 8. Holder control key

UDLR (Up, Down, Left, Right) arrow/it controls UDLR movement of the holder.

[HOME] key: Holder returns to center position or enters the next level

menu.

### 9. Backlight compensation control key

Backlight on/off: Turn on or off backlight.

10. Menu key: Enter/exit OSD menu or return to previous level menu.

### 11. Set infrared remote control address of camera

[\*] + [#] + [F1] : # 1 address    [\*] + [#] + [F2] : # 2 address

[\*] + [#] + [F3] : #3 address    [\*] + [#] + [F4] : #4 address

### 12. Combination key functions

1) [#] + [#] + [#] : Cancel all presets

2) [\*] + [#] + [6] : Restore factory settings

3) [\*] + [#] + [9] : Shift between front and upside down installation

4) [\*] + [#] + auto: Enter aging mode

5) [\*] + [#] + [3] : Set menu into Chinese

6) [\*] + [#] + [4] : Set menu into English

7) [\*] + [#] + manual: Restore default IP, user name, password

8) [#] + [#] + [0] : Shift video format 1080P60

9) [#] + [#] + [1] : Shift video format 1080P50

10) [#] + [#] + [2] : Shift video format 1080I60

11) [#] + [#] + [3] : Shift video format 1080I50

12) [#] + [#] + [4] : Shift video format 720P60

13) [#] + [#] + [5] : Shift video format 720P50

14) [#] + [#] + [6] : Shift video format 1080P30

15) [#] + [#] + [7] : Shift video format 1080P25

16) [#] + [#] + [8] : Shift video format 720P30

17) [#] + [#] + [9] : Shift video format 720P25

## 7.2 Use remote control

After normal start of the camera, it receives infrared command and execute. Press down remote control key, receiving indicator of remote control flashes, release the key, the indicator stops flashing. User can set preset, read position, horizontal and vertical motion by infrared remote control. Description of keys:

1. Key press mentioned in this manual means press and release the key on remote control. For example, “press [HOME] key” means press down [HOME] key and release. If long press is needed, it will be specified specially.
2. Operation of combination keys mentioned in this manual means operating such keys in order. For example, “press [\*] + [#] + [F1]” means press [\*] first, then [#], and [F1] at last.

### 1) Select camera



Select address number of camera to be controlled.

### 2) Control holder



Rotate upward: Press [▲] ; rotate downward: Press [▼] ]  
Rotate to left: Press [◀] ; rotate to right: Press [▶] ]  
Center position: Press [HOME]  
Long press UDLR key, it will rotate from low speed to high speed continuously, until it reaches the destination; release in the middle of the journey, it will stop movement.

### 3) Set, cancel, call preset



1. Save preset: Press [Set preset], then press any number key from 0 to 9, it will reset a preset corresponding to the number key.

Note: with remote control, it can set 10 presets at most.

2. Call preset: Press number key 0~9 directly, it will call preset which has been saved.

**Note:** If this key has no preset, this operation is invalid.

3. Cancel preset: Press [cancel preset], then press any number from 0 to 9, it will cancel preset corresponding to the number.

Note: Press [#] three times in a row, it will cancel all presets.

### 4) Zoom control



Zoom in: Press [zoom +]

Zoom out: Press [zoom -]

Long press these keys will enable continuous zoom in/zoom out; release midway will stop zoom.

### 5) Focusing control



Focusing in: Press [focusing +] key (only valid in manual focusing mode)

Focusing out: Press [focusing -] key (only valid in manual focusing mode)

Long press these keys will enable continuous focusing in/focusing out, release midway will stop focusing.

## 7) Set infrared remote control address of camera

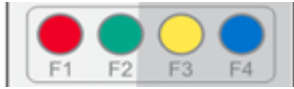

[F1] stop tracking (everytime when use remote control, please stop tracking first)

[F2] Start tracking

[\*] + [#] + [F1] : Set up #1 address

[\*] + [#] + [F2] : Set up #2 address

[\*] + [#] + [F3] : Set #3 address

[\*] + [#] + [F4] : Set up #4 address

# 8 Set menu

## 8.1 Main menu

In normal image, press [MENU] key, the screen displays the menu content, use the arrow to point to the desired item.

<p>主菜单 =====</p> <p>语言设置 / Language 中文/Chinese (设置) (相机参数) (P/T/Z) (视频格式) (版本) (恢复出厂默认值)</p> <p>[↑ ↓]选择                      [←→]修改 [菜单]返回                      [Home]确定</p>	<p>MENU =====</p> <p>Language                      English (Setup) (Camera) (P/T/Z) (Video Format) (Version) (Restore Default)</p> <p>[↑ ↓]Select    [←→] Change Value [Menu]Back                      [Home]OK</p>
--	---

**Language settings / Language:** Select menu language, Chinese/English

**Settings:** Enter submenu of system parameter settings

**Camera parameters:** Enter submenu of camera parameter settings

**P/T/Z:** Enter submenu item of holder parameter settings

**Version:** Enter submenu of Version

**Restore default:** Enter restore default, select “yes” or “no” restore default

[↑ ↓] Select: Press [↑ ↓] to select menu item

[←→]Change value: Press [←→] to change value

[Menu] return: Press menu key to return

[Home] OK: Press [Home] key to confirm



## 8.2 System parameter settings

On the main menu, move the cursor to (Settings), press [HOME] key to enter Settings page, as shown below.

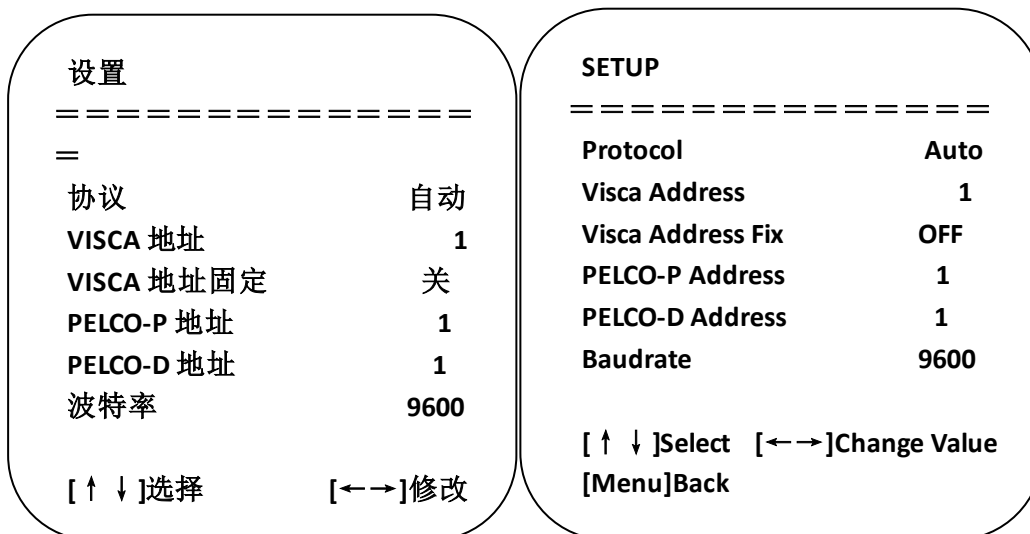

**Protocol:** Protocol type VISCA/PELCO-P/PELCO-D/auto      **Communication address:** VISCA=1~7; PELCO-P = 1~64; PELCO-D = 1~64

**Baud rate:** Set item: 2400/4800/9600/115200      **VISCA address fix:** Set item: On/off

## 8.3 Camera parameter settings

On the main menu, move the cursor to (CAMERA), press [HOME] key to enter CAMERA page, as shown below.

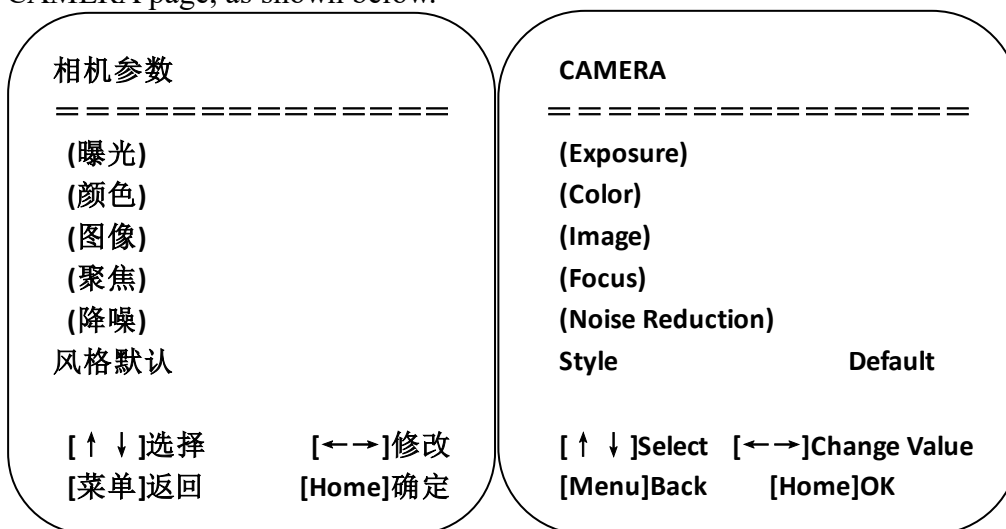

**Exposure:** Enter exposure submenu item      **Image:** Enter image submenu item      **Color:** Enter color submenu item

**Focus:** Enter focus submenu item      **Noise reduction:** Enter noise reduction submenu item      **Style:** Default, standard, clear, bright, gentle

## 1) Exposure

On CAMERA menu, move the cursor to (EXPOSURE), press [HOME] key to enter exposure page, as shown below.

曝光		EXPOSURE	
=====		=====	
曝光模式	自动	Mode	Auto
曝光补偿	关	EV	OFF
背光	关	BLC	OFF
抗闪烁	50Hz	Flicker	50Hz
增益限制	3	G.Limit	3
动态范围	2	DRC	2
[↑ ↓]选择	[←→]修改	[↑ ↓]Select	[←→]Change Value
[菜单]返回		[Menu]Back	

**Mode:** Options: Auto, manual, shutter priority, aperture priority, brightness priority

**EV:** Options: On/off (only valid in auto mode)

**Compensation grade: Options:** -7~7 (only valid in auto mode when “EV” is on.)

**BLC:** Options: On/off (only valid in auto mode) **DRC:** Options: 1~8, off

**Flicker:** Options: Off, 50Hz, 60Hz (valid in auto, shutter priority and brightness priority modes)

**G. Limit:** Options: 0~15(valid in auto, shutter priority and brightness priority modes)

**Shutter priority:** Options: 1/25, 1/30, 1/50, 1/60, 1/90, 1/100, 1/120, 1/180, 1/250, 1/350, 1/500, 1/1,000, 1/2000, 1/3000, 1/4000, 1/6000, 1/10000 (valid in manual and shutter priority modes)

**Aperture priority:** Options: Off, F11.0, F9.6, F8.0, F6.8, F5.6, F4.8, F4.0, F3.4, F2.8, F2.4, F2.0, F1.8 (valid in manual and aperture priority modes) **Brightness:** Options: 0~23 (only valid in brightness priority mode.)

## 2) Color

On CAMERA menu, move the cursor to (COLOR), press [HOME] key to enter COLOR page, as shown below.

颜色		COLOR	
=====		=====	
白平衡模式	自动	WB Mode	Auto
红微调	0	RG Tuning	0
蓝微调	0	BG Tuning	0
饱和度	100%	Saturation	100%
色度	7	Hue	7
白平衡灵敏度	低	AWB Sensitivity	Low
[↑ ↓]选择	[←→]修改	[↑ ↓]Select	[←→]Change Value
[菜单]返回		[Menu]Back	

WB Mode: Options: auto, 3000K, 4000K, 5000K, 6500K, manual, one-key white balance.

**RG Tuning:** Options: -10~10 (only valid in auto mode)    **BG Tuning:** Options: -10~10 (only valid in auto mode)

**Red gain:** Options: 0~255 (only valid in manual mode)    **Blue gain:** Options: 0~255 (only valid in manual mode)

**Saturation:** Options: 60%, 70%, 80%, 90%, 100%, 110%, 120%, 130%, 140%, 150%, 160%, 170%, 180%, 190%, 200%    **Hue:** Options: 0~14

**AWB Sensitivity:** Options: high, medium, low (only valid in auto mode)

### 3) Image

On CAMERA menu, move the cursor to (IMAGE), press [HOME] to enter IMAGE page, as shown below.

图像		IMAGE	
=====		=====	
亮度	7	Brightness	7
对比度	7	Contrast	7
锐度	4	Sharpness	4
水平翻转	关	Flip-H	OFF
垂直翻转	关	Flip-V	OFF
黑白模式	彩色	B&W-Mode	Color
伽玛曲线	默认	Gamma	Default
电子变倍	关	DZoom	OFF
DCI	关	DCI	OFF
[↑ ↓]选择	[←→]修改	[↑ ↓]Select	[←→]Change Value
[菜单]返回		[Menu]Back	

**Brightness:** Options: 0~14

**Contrast:** Options: 0~14

**Sharpness:** Options: 0~15

**Flip-H:** Options: on/off

**Flip-V:** Options: on/off

**B&W-Mode:** Options: color, black & white

**Gamma:** Options: default, 0.45, 0.50, 0.55, 0.63

**Dzoom:** Options: on/off **DCI: dynamic contrast,** options, off, 1~8

#### 4) Focus

On CAMER menu, move the cursor to (FOCUS), press [HOME] key to enter FOCUS page, as shown below.

<b>聚焦</b> ===== 聚焦模式                  自动 聚焦区域                    中 聚焦灵敏度                低  [↑↓]选择                  [←→]修改 [菜单]返回	<b>FOCUS</b> ===== Focus Mode                Auto AF-Area                    Center AF-Sensitivity            Low  [↑↓]Select    [←→]Change Value [Menu]Back
---	---

**Focus mode:** Options: auto/manual

**AF-Area:** Options: up/center/low

**AF-Sensitivity:** Options: high/medium/low

#### 5) Noise reduction

On CAMERA menu, move the cursor to (Noise reduction), press [HOME] key to enter Noise reduction page, as shown below.

<b>降噪</b> ===== 2D 降噪                    3 3D 降噪                    3 动态坏点                    关闭  [↑↓]选择                  [←→]修改 [菜单]返回	<b>NOISE REDUCTION</b> ===== NR-2D                      3 NR-3D                      3 Dynamic Hot Pixel        OFF  [↑↓]Select    [←→]Change Value [Menu]Back
--	---

**NR-2D:** Options: auto, off, 1~7

**NR-3D:** Options: off, 1~8

**Dynamic hot pixel:** Options: off, 1~5

## 8.4 P/T/Z

On the main menu, move the cursor to (P/T/Z), press [HOME] key to enter P/T/Z page, as shown below.

<b>P/T/Z</b> ===== 景深比例                    开 变倍速度                    8 图像冻结                    关 加速曲线                    慢  [↑↓]选择                  [←→]修改 [菜单]返回	<b>P/T/Z</b> ===== Speed by zoom              ON Zoom speed                 8 Image Freezing            OFF Acc Curve                    Slow  [↑↓]Select    [←→]Change Value [Menu]Back
---	--

**Speed by zoom:** It only works on remote control, on, off; when camera zooms in, remote control will make holder rotate at lower speed.

**Zoom speed:** Set speed for remote control camera zoom, 1~8     **Image freezing:** Options: On/off

**Acc Curve:** Options: Quick/slow

## 8. 5 Video format

On the main menu, move the cursor to (VIDEO FORMAT), press [HOME] key to enter VIDEO FORMAT page, as shown below.

视频格式		VIDEO FORMAT	
=====		=====	
1080P60	1080P50	1080P60	1080P50
1080I60	1080I50	1080I60	1080I50
1080P30	1080P25	1080P30	1080P25
720P60	720P50	720P60	720P50
720P30	720P25	720P30	720P25
1080P59.94	1080I59.94	1080P59.94	1080I59.94
1080P29.97	720P59.94	1080P29.97	720P59.94
720P29.97		720P29.97	
[↑ ↓]选择		[↑ ↓]Select	
[菜单]返回	[Home]确定	[Menu]Back	[Home]OK

Note: only when rotation dial-up is at F will ST model menu show this item.

S version: 1080P60 downward compatibility; M version: 1080P30 downward compatibility

Change parameter value in the menu. To save value when power off, exit menu.

## 8. 6 Version

On the main menu, move the cursor to (Version), press [HOME] key to enter Version page. Version information varies from product model and date of production. Version information contains version number and version upgrade time.

MCU version: It displays MCU version information.

Camera version: It displays camera version information.

Focus version: It displays focus version information.

## 8. 7 Restore default

On the main menu, move the cursor to (restore), press [HOME] key to enter Restore page, as shown below.

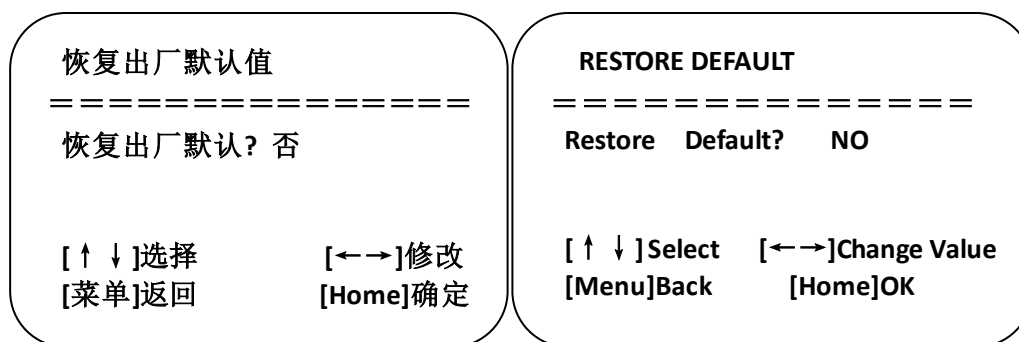

Restore default : Options : Yes/no (color style and video format can't be restored default).

**Note:** If remote address used before is not 1, but any one from 2, 3 and 4, after restoring all parameters or system parameters, device address corresponding to the remote control will be reset to 1. At this moment, it is needed to change remote control address to 1, that is, press Camera and select [1], control will function.

## 9 Technical parameters

Parameter/model	Model-12	Model-20
<b>Tracking camera, lens parameters</b>		
<b>Image sensor</b>	1/2.8inch high quality CMOS sensor	
<b>Effective pixels</b>	2,070,000 16: 9	
<b>Video signal</b>	1080P60/50/30/25/59.94/29.971080I60/50/59.94720P60/50/30/25 /59.94/29.97	
<b>Lens optics zoom</b>	12X optical zoom f=3.9~46.1mm	20X optical zoom f=4.7~94mm
<b>Visual angle</b>	6.3° (narrow angle) ~72.5° (wide angle)	2.9° (narrow angle) ~55.4° (wide angle)
<b>Aperture coefficient</b>	F1.8~F2.4	F1.6 ~ F3.5
<b>Digit zoom</b>	X10	
<b>Minimum illumination</b>	0.5Lux(F1.8, AGC ON)	
<b>Digit noise reduction</b>	2D & 3D digit noise reduction	
<b>White balance</b>	Manual/auto/one-key white balance /3000K/ 4000K/5000K/6500K	
<b>Focus</b>	Auto/manual	
<b>Aperture</b>	Auto/manual	
<b>Electronic shutter</b>	Auto/manual	
<b>Backlight compensation</b>	On/off	
<b>Wide dynamic</b>	Off/dynamic grade adjustment	
<b>Video regulation</b>	Brightness, hue, saturation, contrast ratio, sharpness, Gamma	
<b>Signal to noise ratio</b>	>55dB	

<b>Panoramic lens</b>	
<b>Image sensor</b>	1/2.8inch high quality CMOS sensor
<b>Effective pixels</b>	2,100,000
<b>Lens</b>	Manual focus
<b>Output port</b>	SDI Model: SDI, LAN, HDMI/U3 Model: HDMI, USB3.0, LAN
<b>Field angle (D/H/V)</b>	112°/82°/57.6°

<b>Input/output port and support protocol</b>	
<b>Ports</b>	SDI Model: SDI, LAN, 2-channel 3.5mm linear audio input, RS232 (input) HDMI/U3 Model: HDMI (support video and audio output), USB3.0, LAN, 2-channel 3.5mm linear audio input, RS232 (input)

<b>Network port</b>	100M internet access (10/100BASE-TX) 5GWiFi(optional), support network VISCA control protocol
<b>Network protocol</b>	RTSP, RTMP, ONVIF, GB/T28181
<b>Compression image code stream</b>	Dual stream output
<b>Video compression format</b>	H.265, H.264
<b>Control signal port</b>	RS-232/485
<b>Control protocol</b>	VISCA/Pelco-D/Pelco-P; Baud rate: 115,200/9,600/4,800/2,400bps
<b>Audio input port</b>	Dual track 3.5mm linear input
<b>Audio compression format</b>	AAC, MP3, PCM
<b>Power port</b>	HEC3800 power socket (DC12V)

<b>Pan/tilt parameters</b>	
<b>Horizontal rotation</b>	-170°~+170°
<b>Vertical rotation</b>	-30°~+90°
<b>Horizontal control speed</b>	0.1 ~100°/s
<b>Vertical control speed</b>	0.1~45°/s
<b>Preset speed</b>	Horizontal: 100°/s, vertical:45°/s
<b>Preset quantity</b>	User can set 255 presets at most (10 pcs of mobile control)

<b>Other parameters</b>	
<b>Power adapter</b>	Input AC110V-AC220V output DC12V/2.5A
<b>Input voltage</b>	DC12V±10%
<b>Input current</b>	1.5A (maximum)
<b>Power consumption</b>	18W (maximum)
<b>Storage temperature</b>	-10℃~+60℃
<b>Storage humidity</b>	20%~95%
<b>Operating temperature</b>	-10℃~+50℃
<b>Operating humidity</b>	20%~80%
<b>Dimension (WxHxD)</b>	254mm X 144mm X 174mm
<b>Weight (approx.)</b>	1.50kg
<b>Operating environment</b>	Indoor
<b>Remote maintenance (network port)</b>	Remote upgrade, restart and reset
<b>Standard accessories</b>	12V/2.5A power, RS232 control line, remote control, operation manual, warranty card
<b>Optional accessories</b>	Installation support

## 10 VISCA protocol command list

When the camera is operated normally, we can control it via RS232C/RS485 port (VISCA IN).

Parameters of RS232C serial port are as follows:

Baud rate: 2,400/4,800/9,600/115,200bit/s; start bit: 1 bit; digit bit: 8 bits; stop bit: 1 bit; verification bit: none

After powering on, camera rotates to left bottom first, and then returns to middle. Zoom lens zooms out to the furthest and zooms in to the nearest, and finishes self-inspection. If the camera saves #0 preset, after initialization, camera will go to #0 preset. Now user can use a serial port command to control the camera.

### Return command





Ack/Completion Message		
	Command package	Notes
ACK	z0 41 FF	Returned when the command is accepted.
Completion	z0 51 FF	Returned when the command has been executed.

z = camera address+8

Error Messages		
	Command package	Notes
Syntax Error	z0 60 02 FF	Returned when the command format is different or when a command with illegal command parameters is accepted
Command Not Executable	z0 61 41 FF	Returned when a command cannot be executed due to current conditions. For example, when commands controlling the focus manually are received during auto focus.

## Control command

Command	Function	Command package	Notes
AddressSet	Broadcast	88 30 01 FF	Address setting
IF_Clear	Broadcast	88 01 00 01 FF	I/F Clear
CommandCancel		8x 21 FF	
CAM_Power	On	8x 01 04 00 02 FF	Power ON/OFF
	Off	8x 01 04 00 03 FF	
CAM_Zoom	Stop	8x 01 04 07 00 FF	p = 0(low) - 7(high) pqrs: Zoom Position
	Tele (Standard)	8x 01 04 07 02 FF	
	Wide (Standard)	8x 01 04 07 03 FF	
	Tele (Variable)	8x 01 04 07 2p FF	
	Wide (Variable)	8x 01 04 07 3p FF	
	Direct	8x 01 04 47 0p 0q 0r 0s FF	
CAM_Focus	Stop	8x 01 04 08 00 FF	p = 0(low) - 7(high) pqrs: Focus Position
	Far(Standard)	8x 01 04 08 02 FF	
	Near(Standard)	8x 01 04 08 03 FF	
	Far(Variable)	8x 01 04 08 2p FF	
	Near (Variable)	8x 01 04 08 3p FF	
	Direct	8x 01 04 48 0p 0q 0r 0s FF	
	Auto Focus	8x 01 04 38 02 FF	
	Manual Focus	8x 01 04 38 03 FF	
CAM_Zoom Focus	Direct	8x 01 04 47 0p 0q 0r 0s 0t 0u 0v 0w FF	pqrs: Zoom Position tuvw: Focus Position
CAM_WB	Auto	8x 01 04 35 00 FF	
	3000K	8x 01 04 35 01 FF	
	4000k	8x 01 04 35 02 FF	
	One Push mode	8x 01 04 35 03 FF	
	5000k	8x 01 04 35 04 FF	
	Manual	8x 01 04 35 05 FF	
	6500k	8x 01 04 35 06 FF	
CAM_RGain	Reset	8x 01 04 03 00 FF	Manual Control of R Gain
	Up	8x 01 04 03 02 FF	
	Down	8x 01 04 03 03 FF	
	Direct	8x 01 04 43 00 00 0p 0q FF	pq: R Gain
CAM_Bgain	Reset	8x 01 04 04 00 FF	

Command	Function	Command package	Notes
	Up	8x 01 04 04 02 FF	Manual Control of B Gain
	Down	8x 01 04 04 03 FF	
	Direct	8x 01 04 44 00 00 0p 0q FF	pq: B Gain
CAM_AE	Full Auto	8x 01 04 39 00 FF	Automatic Exposure mode
	Manual	8x 01 04 39 03 FF	Manual Control mode
	Shutter priority	8x 01 04 39 0A FF	Shutter Priority Automatic Exposure mode
	Iris priority	8x 01 04 39 0B FF	Iris Priority Automatic Exposure mode
	Bright	8x 01 04 39 0D FF	Bright mode
CAM_Shutter	Reset	8x 01 04 0A 00 FF	Shutter Setting
	Up	8x 01 04 0A 02 FF	
	Down	8x 01 04 0A 03 FF	
	Direct	8x 01 04 4A 00 00 0p 0q FF	pq: Shutter Position
CAM_Iris	Reset	8x 01 04 0B 00 FF	Iris Setting
	Up	8x 01 04 0B 02 FF	
	Down	8x 01 04 0B 03 FF	
	Direct	8x 01 04 4B 00 00 0p 0q FF	pq: Iris Position
CAM_Gain	Reset	8x 01 04 0C 00 FF	Gain Setting
	Up	8x 01 04 0C 02 FF	
	Down	8x 01 04 0C 03 FF	
	Direct	8x 01 04 0C 00 00 0p 0q FF	pq: Gain Position
CAM_Bright	Reset	8x 01 04 0D 00 FF	Bright Setting
	Up	8x 01 04 0D 02 FF	
	Down	8x 01 04 0D 03 FF	
	Direct	8x 01 04 4D 00 00 0p 0q FF	pq: Bright Position
CAM_ExpComp	On	8x 01 04 3E 02 FF	Exposure Compensation ON/OFF
	Off	8x 01 04 3E 03 FF	
	Reset	8x 01 04 0E 00 FF	Exposure Compensation Amount Setting
	Up	8x 01 04 0E 02 FF	
	Down	8x 01 04 0E 03 FF	
	Direct	8x 01 04 4E 00 00 0p 0q FF	
CAM_Back Light	On	8x 01 04 33 02 FF	Back Light Compensation
	Off	8x 01 04 33 03 FF	
CAM_NR (2D)		8x 01 04 53 0p FF	P=0-7 0:OFF
CAM_NR (3D)		8x 01 04 54 0p FF	P=0-8 0:OFF
CAM_Gamma		8x 01 04 5B 0p FF	p = 0 - 4 0: Default 1: 0.45 2: 0.50 3: 0.55 4: 0.63
CAM_Flicker	OFF	8x 01 04 23 00 FF	OFF
	50HZ	8x 01 04 23 01 FF	50HZ
	60HZ	8x 01 04 23 02 FF	60HZ
CAM_Aperture	Reset	8x 01 04 02 00 FF	Aperture Control
	Up	8x 01 04 02 02 FF	
	Down	8x 01 04 02 03 FF	
	Direct	8x 01 04 42 00 00 0p 0q FF	pq: Aperture Gain

Command	Function	Command package	Notes
CAM_Memory	Reset	8x 01 04 3F 00 pq FF	pq: Memory Number(=0 to 254) Corresponds to 0 to 9 on the Remote Commander
	Set	8x 01 04 3F 01 pq FF	
	Recall	8x 01 04 3F 02 pq FF	
CAM_LR_Reverse	On	8x 01 04 61 02 FF	Image Flip Horizontal ON/OFF
	Off	8x 01 04 61 03 FF	
CAM_PictureFlip	On	8x 01 04 66 02 FF	Image Flip Vertical ON/OFF
	Off	8x 01 04 66 03 FF	
CAM_ColorSaturation	Direct	8x 01 04 4900 00 00 0p FF	P=0-E 0:60%           1:70% 2:80%           3:90% 4:100% 5:110%         6:120% 7:130%         8:140% 9:150%         10:160% 11:160%        12:180% 13:190%        14:200%
CAM_IDWrite		8x 01 04 22 0p 0q 0r 0s FF	pqrs: Camera ID (=0000 to FFFF)
SYS_Menu	ON	8x 01 04 06 06 02 FF	Turn on the menu screen
	OFF	8x 01 04 06 06 03 FF	Turn off the menu screen
IR_Receive	ON	8x 01 0608 02 FF	IR(remote commander)receive On/Off
	OFF	8x 01 0608 03 FF	
IR_ReceiveReturn	On	8x 01 7D 01 03 00 00 FF	IR(remote commander)receive message via the VISCA communication ON/OFF
	Off	8x 01 7D 01 13 00 00 FF	
CAM_SettingReset	Reset	8x 01 04 A0 10 FF	Reset Factory Setting
CAM_Brightness	Direct	8x 01 04 A1 00 00 0p 0q FF	pq: Brightness Position
CAM_Contrast	Direct	8x 01 04 A2 00 00 0p 0q FF	pq: Contrast Position
CAM_Flip	OFF	8x 01 04 A4 00 FF	Single Command For Video Flip
	Flip-H	8x 01 04 A4 01 FF	
	Flip-V	8x 01 04 A4 02 FF	
	Flip-HV	8x 01 04 A4 03 FF	
CAM_VideoSystem	Set camera video system	8x 01 06 35 00 0p FF	P: 0~E Video format 0:1080P60 8:720P30 1:1080P50 9:720P25 2:1080i60 A: 1080P59.94 3:1080i50 B: 1080i59.94 4:720P60 C: 720P59.94 5:720P50 D: 1080P29.97 6:1080P30 E: 720P29.97 7:1080P25

Command	Function	Command package	Notes
Pan_tiltDrive	Up	8x 01 06 01 VV WW 03 01 FF	VV: Pan speed 0x01 (low speed) to 0x18 (high speed) WW: Tilt speed 0x01 (low speed) to 0x14 (high speed) YYYY: Pan Position ZZZZ: Tilt Position
	Down	8x 01 06 01 VV WW 03 02 FF	
	Left	8x 01 06 01 VV WW 01 03 FF	
	Right	8x 01 06 01 VV WW 02 03 FF	
	Upleft	8x 01 06 01 VV WW 01 01 FF	
	Upright	8x 01 06 01 VV WW 02 01 FF	
	DownLeft	8x 01 06 01 VV WW 01 02 FF	
	DownRight	8x 01 06 01 VV WW 02 02 FF	
	Stop	8x 01 06 01 VV WW 03 03 FF	
	AbsolutePosition	8x 01 06 02 VV WW 0Y 0Y 0Y 0Y 0Z 0Z 0Z 0Z FF	
	RelativePosition	8x 01 06 03 VV WW 0Y 0Y 0Y 0Y 0Z 0Z 0Z 0Z FF	
	Home	8x 01 06 04 FF	
Reset	8x 01 06 05 FF		
Pan-tiltLimitSet	Set	8x 01 06 07000W 0Y 0Y 0Y 0Y 0Z 0Z 0Z 0Z FF	W:1 UpRight 0:DownLeft YYYY: Pan Limit Position(TBD) ZZZZ: Tilt Limit Position(TBD)
	Clear	8x 01 06 07010W 07 0F 0F 0F 07 0F 0F 0F FF	

### Search command

Command	Command package	Return package	Notes
CAM_PowerInq	8x 09 04 00 FF	y0 50 02 FF	On
		y0 50 03 FF	Off(Standby)
CAM_ZoomPosInq	8x 09 04 47 FF	y0 50 0p 0q 0r 0s FF	pqrs: Zoom Position
CAM_FocusAFModeInq	8x 09 04 38 FF	y0 50 02 FF	Auto Focus
		y0 50 03 FF	Manual Focus
CAM_FocusPosInq	8x 09 04 48 FF	y0 50 0p 0q 0r 0s FF	pqrs: Focus Position
CAM_WBModeInq	8x 09 04 35 FF	y0 50 00 FF	Auto
		y0 50 01 FF	3000K
		y0 50 02 FF	4000K
		y0 50 03 FF	One Push Mode
		y0 50 04 FF	5000K
		y0 50 05 FF	Manual
CAM_RGainInq	8x 09 04 43 FF	y0 50 00 00 0p 0q FF	pq: R Gain
CAM_BGainInq	8x 09 04 44 FF	y0 50 00 00 0p 0q FF	pq: B Gain
CAM_AEModeInq	8x 09 04 39 FF	y0 50 00 FF	Full Auto
		y0 50 03 FF	Manual
		y0 50 0A FF	Shutter priority
		y0 50 0B FF	Iris priority
CAM_ShutterPosInq	8x 09 04 4A FF	y0 50 00 00 0p 0q FF	pq: Shutter Position
CAM_IrisPosInq	8x 09 04 4B FF	y0 50 00 00 0p 0q FF	pq: Iris Position
CAM_BrightPosInq	8x 09 04 4D FF	y0 50 00 00 0p 0q FF	pq: Bright Position
CAM_ExpCompModeInq	8x 09 04 3E FF	y0 50 02 FF	On
		y0 50 03 FF	Off
CAM_ExpCompPosInq	8x 09 04 4E FF	y0 50 00 00 0p 0q FF	pq: ExpComp Position
CAM_BacklightModeInq	8x 09 04 33 FF	y0 50 02 FF	On
		y0 50 03 FF	Off
CAM_NRLevel(2D) Inq	8x 09 04 53 FF	y0 50 0p FF	P: 2DNRLLevel
CAM_NRLevel(3D) Inq	8x 09 04 54 FF	y0 50 0p FF	P:3D NRLevel
CAM_FlickerModeInq	8x 09 04 55 FF	y0 50 0p FF	p: Flicker Settings (0: OFF, 1: 50Hz, 2:60Hz)
CAM_ApertureInq	8x 09 04 42 FF	y0 50 00 00 0p 0q FF	pq: Aperture Gain
CAM_PictureEffectModeInq	8x 09 04 63 FF	y0 50 00 FF	Off
		y0 50 04 FF	B&W
CAM_MemoryInq	8x 09 04 3F FF	y0 50 0p FF	p: Memory number

			last operated.
SYS_MenuModeInq	8x 09 0606 FF	y0 50 02 FF	On
		y0 50 03 FF	Off
CAM_LR_ReverseInq	8x 09 04 61 FF	y0 50 02 FF	On
		y0 50 03 FF	Off
CAM_PictureFlipInq	8x 09 04 66 FF	y0 50 02 FF	On
		y0 50 03 FF	Off
CAM_ColorSaturationInq	8x 09 04 49 FF	y0 50 00 00 00 0p FF	p: Color Gain setting 0h (60%) to Eh (200%)
CAM_IDInq	8x 09 04 22 FF	y0 50 0p FF	p: Gamma ID
IR_ReceiveInq	8x 09 0608 FF	y0 50 02 FF	On
		y0 50 03 FF	Off
IR_ReceiveReturn		y0 077D 01 04 00 FF	Power ON/OFF
		y0 077D 01 04 07 FF	Zoom tele/wide
		y0 077D 01 04 38 FF	AF ON/OFF
		y0 077D 01 04 33 FF	Camera Backlight
		y0 077D 01 04 3F FF	Camera_Memery
		y0 077D 01 06 01 FF	Pan_titleDriver
CAM_BrightnessInq	8x 09 04A1 FF	y0 50 00 00 0p 0q FF	pq: Brightness Position
CAM_ContrastInq	8x 09 04A2 FF	y0 50 00 00 0p 0q FF	pq: Contrast Position
CAM_FlipInq	8x 09 04A4 FF	y0 50 00 FF	Off
		y0 50 01 FF	Flip-H
		y0 50 02 FF	Flip-V
		y0 50 03 FF	Flip-HV
CAM_GammaInq	8x 09 04 5B FF	y0 50 0p FF	p: Gamma setting
CAM_VersionInq	8x 09 00 02 FF	y0 50 ab cd mn pq rs tu vw FF	ab cd: vender ID ( 0220 ) mn pq: model ID ST ( 0951 ) U3 (3950) rs tu : ARM Version vw : reserve
VideoSystemInq	8x 09 06 23 FF	y0 50 0p FF	P: 0~E Video format 0:1080P60 8:720P30 1:1080P50 9:720P25 2:1080i60 A: 1080P59.94 3:1080i50 B: 1080i59.94 4:720P60 C: 720P59.94 5:720P50 D: 1080P29.97 6:1080P30 E: 720P29.97 7:1080P25
Pan-tiltMaxSpeedInq	8x 09 06 11 FF	y0 50 ww zz FF	ww: Pan Max Speedzz: Tilt Max Speed
Pan-tiltPosInq	8x 09 06 12 FF	y0 50 0w 0w 0w 0w 0z 0z 0z 0z FF	www: Pan Positionzz zz: Tilt Position

Note: [x] on table above means address of camera to be operated, [y] = [x+8].

# 11 Pelco-D protocol command list

Function	Byte1	Byte2	Byte3	Byte4	Byte5	Byte6	Byte7
Up	0xFF	Address	0x00	0x08	Pan Speed	Tilt Speed	SUM
Down	0xFF	Address	0x00	0x10	Pan Speed	Tilt Speed	SUM
Left	0xFF	Address	0x00	0x04	Pan Speed	Tilt Speed	SUM
Right	0xFF	Address	0x00	0x02	Pan Speed	Tilt Speed	SUM
Upleft	0xFF	Address	0x00	0x0C	Pan Speed	Tilt Speed	SUM
Upright	0xFF	Address	0x00	0x0A	Pan Speed	Tilt Speed	SUM
DownLeft	0xFF	Address	0x00	0x14	Pan Speed	Tilt Speed	SUM
DownRight	0xFF	Address	0x00	0x12	Pan Speed	Tilt Speed	SUM
Zoom In	0xFF	Address	0x00	0x20	0x00	0x00	SUM
Zoom Out	0xFF	Address	0x00	0x40	0x00	0x00	SUM
Focus Far	0xFF	Address	0x00	0x80	0x00	0x00	SUM
Focus Near	0xFF	Address	0x01	0x00	0x00	0x00	SUM
Stop	0xFF	Address	0x00	0x00	0x00	0x00	SUM
Set Preset	0xFF	Address	0x00	0x03	0x00	Preset ID	SUM
Clear Preset	0xFF	Address	0x00	0x05	0x00	Preset ID	SUM
Call Preset	0xFF	Address	0x00	0x07	0x00	Preset ID	SUM
Query Pan Position	0xFF	Address	0x00	0x51	0x00	0x00	SUM
Query Pan Position Response	0xFF	Address	0x00	0x59	Value High Byte	Value Low Byte	SUM
Query Tilt Position	0xFF	Address	0x00	0x53	0x00	0x00	SUM
Query Tilt Position Response	0xFF	Address	0x00	0x5B	Value High Byte	Value Low Byte	SUM
Query Zoom Position	0xFF	Address	0x00	0x55	0x00	0x00	SUM
Query Zoom Position Response	0xFF	Address	0x00	0x5D	Value High Byte	Value Low Byte	SUM

# 12 Pelco-P protocol command list

Function	Byte1	Byte2	Byte3	Byte4	Byte5	Byte6	Byte7	Byte8
Up	0xA0	Address	0x00	0x08	Pan Speed	Tilt Speed	0xAF	XOR
Down	0xA0	Address	0x00	0x10	Pan Speed	Tilt Speed	0xAF	XOR
Left	0xA0	Address	0x00	0x04	Pan Speed	Tilt Speed	0xAF	XOR
Right	0xA0	Address	0x00	0x02	Pan Speed	Tilt Speed	0xAF	XOR
Upleft	0xA0	Address	0x00	0x0C	Pan Speed	Tilt Speed	0xAF	XOR
Upright	0xA0	Address	0x00	0x0A	Pan Speed	Tilt Speed	0xAF	XOR
DownLeft	0xA0	Address	0x00	0x14	Pan Speed	Tilt Speed	0xAF	XOR
DownRight	0xA0	Address	0x00	0x12	Pan Speed	Tilt Speed	0xAF	XOR
Zoom In	0xA0	Address	0x00	0x20	0x00	0x00	0xAF	XOR
Zoom Out	0xA0	Address	0x00	0x40	0x00	0x00	0xAF	XOR
Stop	0xA0	Address	0x00	0x00	0x00	0x00	0xAF	XOR
Focus Far	0xA0	Address	0x01	0x00	0x00	0x00	0xAF	XOR
Focus Near	0xA0	Address	0x02	0x00	0x00	0x00	0xAF	XOR
Set Preset	0xA0	Address	0x00	0x03	0x00	Preset ID	0xAF	XOR
Clear Preset	0xA0	Address	0x00	0x05	0x00	Preset ID	0xAF	XOR
Call Preset	0xA0	Address	0x00	0x07	0x00	Preset ID	0xAF	XOR
Query Pan Position	0xA0	Address	0x00	0x51	0x00	0x00	0xAF	XOR
Query Pan Position Response	0xA0	Address	0x00	0x59	Value High Byte	Value Low Byte	0xAF	XOR
Query Tilt Position	0xA0	Address	0x00	0x53	0x00	0x00	0xAF	XOR
Query Tilt Position Response	0xA0	Address	0x00	0x5B	Value High Byte	Value Low Byte	0xAF	XOR
Query Zoom Position	0xA0	Address	0x00	0x55	0x00	0x00	0xAF	XOR
Query Zoom Position Response	0xA0	Address	0x00	0x5D	Value High Byte	Value Low Byte	0xAF	XOR

# 13 Maintenance and troubleshooting

## 13.1 Maintenance

- 1) Please disconnect power of camera if it is not in long-term use. Meanwhile, disconnect AC power adapter from AC socket.
- 2) To avoid scratch, use soft cloth or cotton to wipe off dust on camera case and
- 3) Please clean camera lens with dry soft cloth. If stain persists, use mild detergent to wipe gently. Do not use strong or corrosive detergent which may scratch the lens and affect image result.

## 13.2 Troubleshooting

- 1) No image displayed by video output

Solution: a. Check camera power for connection, and check if power indicator is lit.

b. Power off, restart the device and check if it performs self inspection normally.

c. Check if dial switch at the bottom is in normal operating mode (refer to Table 2.2 and Table 2.3).

d. Check if connection line of video output and video display functions.

- 2) Image is unstable

Solution: a. Check if connection line of video output and video display functions.

- 3) Lens zoom image dithering

Solution: a. Check if camera is installed securely.

b. Check if there is vibrating machine or object nearby the camera.

- 4) Remote control is out of service

Solution: a. Set remote control address to be 1, and check if it works (if the device restores to default, remote control address will be restored to 1).

b. Check if remote control battery is installed or battery is low

c. Check if camera is in normal operating mode (refer to table 2.2 and table 2.3)

d. Check if menu exits. It only works when menu exits; if webpage outputs image, it will not display menu or perform any operation. Menu exits in 30s automatically. Remote control works.

- 5) Serial port is out of control

Solution: a. Check if it is standard control line provided by our company.

b. Check if serial port protocol, baud rate and address are consistent with camera.

c. Check if control line connects correctly.

d. Check if camera is in normal operating mode (refer to table 2.2 and table 2.3).

- 6) Failure to log in webpage

Solution: a. Use display to check if camera outputs image normally.

b. Check if network cable connects correctly (flicker of yellow indicator at internet access means network cable connection is correct).

c. Check if computer adds network segment and if network segment is consistent with camera IP address.

d. Click "start" in computer, select "operate", and enter cmd; click "confirm", DOS command window appears; input ping 192.168.5.163, press Enter,



information below means network connection functions well.



```
管理员: C:\Windows\system32\cmd.exe
Microsoft Windows [版本 6.1.7601]
版权所有 (c) 2009 Microsoft Corporation。保留所有权利。

C:\Users\Administrator>ping 192.168.5.163

正在 Ping 192.168.5.163 具有 32 字节的数据:
来自 192.168.5.163 的回复: 字节=32 时间=1ms TTL=64
来自 192.168.5.163 的回复: 字节=32 时间<1ms TTL=64
来自 192.168.5.163 的回复: 字节=32 时间<1ms TTL=64
来自 192.168.5.163 的回复: 字节=32 时间<1ms TTL=64

192.168.5.163 的 Ping 统计信息:
    数据包: 已发送 = 4, 已接收 = 4, 丢失 = 0 (0% 丢失),
    往返行程的估计时间(以毫秒为单位):
        最短 = 0ms, 最长 = 1ms, 平均 = 0ms

C:\Users\Administrator>
```

## Copyright statement

All the contents in this manual and its copyright are owned by the company. No one is allowed to imitate, copy, or translate this manual without the company's permission. This manual contains no guarantee, standpoint expression or other implies in any form. Product specification and information in this manual is for reference only and subject to change without notice.

All rights reserved. No reprinting without permission.