

IP HD PTZ Color Video Camera

User Manual V1.0

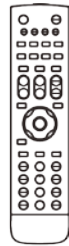
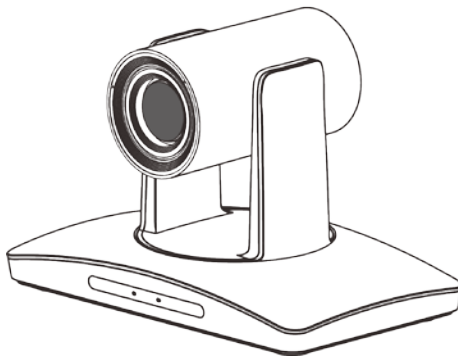

SAFETY NOTICE-IMPORTANT!!!

The following important notes must be followed carefully to run the camera and respective accessories in total safety. The camera and relative accessories are called video system in this section.

- Before installing the camera, please read this manual carefully. Please follow installation instructions indicated in this manual during installation. Please keep this manual for future use.
- The installation should be performed by qualified service personnel or system installers in accordance with all local rules.
- Before powering on the camera, please check the power voltage carefully. Make sure that you are using the correct power source.
- Please put the power cable, video cable and control cable in safe place.
- Do not operate the camera beyond the specified temperature and humidity. Working temperature range of the camera is between 0°C and +40°C. The ambient humidity range is less than 90 % .
- During transporting, avoid violent shake or force to the camera.
- To prevent electric shock, do not remove screws or housing of the camera. There are no self-serviceable parts inside. Refer to qualified service personnel for servicing.
- Video cable and RS485 cable should be kept far away from other cables. Shielded and independent wiring is necessary for video and control cables.
- Never aim the lens of the camera at the sun or other extremely bright objects. Otherwise, it may cause damage.
- When cleaning the camera, please use soft cloth. If the camera is very dirty, wipe it off gently with a soft cloth moistened with a weak solution of water and a neutral kitchen detergent. Wring all liquid from the cloth before wiping the camera, then wipe off all remaining dirt with a soft, dry cloth. Use lens cleaning paper to clean the lens.

- Do not move the camera head manually. In doing so would result in malfunction of the camera. Do not hold the camera head when carrying the video camera.
- This camera is for indoor use only. It is not designed for outdoor use.
- Make sure the camera is not directly exposed to rain and water.
- Make sure the camera is far away from area where radiation, X-rays, strong electric waves, or magnetism is generated.

CONTENTS

ABOUT THE PRODUCT	1
FEATURES	1
LIST OF PARTS & ACCESSORIES	1
MAIN PARTS & INTERFACES	2
DIP SWITCHES SETTINGS	4
REMOTE CONTROLLER	5
INSTALLATION	7
DESKTOP MOUNT INSTALLATION	7
WALL MOUNT INSTALLATION	7
(WALL BRACKET SUPPLIED SEPARATELY)	7
CEILING MOUNT INSTALLATION	8
CONNECTIONS	9
MENU SETTINGS	10
MENU CONFIGURATION	10
MENU EXPLANATION	14
VIDEO	15
EXPOSURE	15
COLOR	16
PAN/TILT/ZOOM	17
SYSTEM	17
STATUS	18
RESTORE DEFAULTS	18
LIST OF SPECIAL PRESET COMMANDS	18
NETWORK CONNECTION	19
LAN CONNECTION	19
WAN CONNECTION	19
CLIENT SOFTWARE INSTRUCTION	22
SEARCH AND LIST THE CAMERA	22
REMOTE CONFIGURATION	23
ANNEX 1 TECHNICAL SPECIFICATIONS	33
ANNEX 2 SIZE AND DIMENSION	35
ANNEX 3 SW1 DEFINITION	36

ABOUT THE PRODUCT

Features

- 1/2.8 inch CMOS sensor, 2.14 megapixel;
- H.265, H.264 video compression;
- 3G-SDI, DVI output;
- Support 1080p60 video output;
- 20x optical zoom, 12x optical zoom;
- 20X: Max FOV: 59.5°;
12X: Max FOV: 72.5°;
- Dual stream, supporting multi-levels configuration of video quality;
- 1 channel audio input and 1 channel output;
- Max. 64G TF card for local storage;
- Precise driving system with high reliability and precision;
- Support multi protocols & control interfaces and Daisy chain;
- OSD menu;
- With IR remote controller;
- Smart AE technology to effectively avoid the interference of complicated lights from projectors ,monitors etc;
- Desktop/Ceiling/ Wall mount optional.

List Of Parts & Accessories

When you open the box, check all accessories according to the packing list.

Camera (1)



Power Adapter (1)

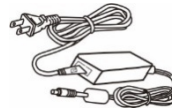

Remote Controller (1)



RS-232 Control Cable (1)



Main Parts & Interfaces

Camera

Front View

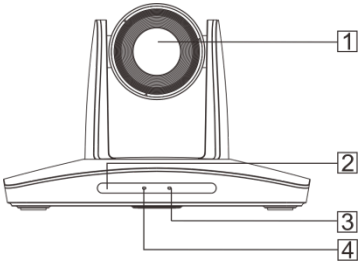

- 1 Camera Module
- 2 IR Sensor
- 3 Power Indicator
- 4 Communication Indicator

Rear View



- 5 TF Card Slot
- 6 USB
- 7 RJ45 (Network)
- 8 HDMI Video Output
- 9 3G-SDI
- 10 Audio
- 11 RS-232IN/IR
- 12 RS-232OUT/RS-485
- 13 Power (DC12V)

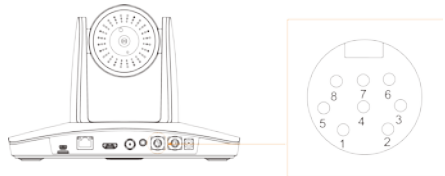

RS-232IN/IR Pin Definition	
Number	Definition
1	/
2	/
3	TXD
4	GND
5	RXD
6	GND
7	IR
8	/

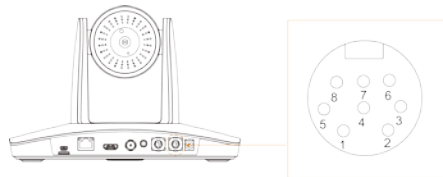

RS-232OUT/RS-485 Pin Definition	
Number	Definition
1	/
2	/
3	TXD
4	GND
5	RXD
6	GND
7	485+
8	485-

Bottom View

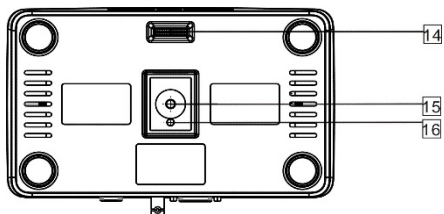

14 DIP Switch

Set camera address, protocol, baud rate, video format and mounting type.

15 Mounting Hole

1/4"inch screw thread for fixing camera.

16 Locating Hole

To define installation direction of camera.

DIP Switches Settings

Before installing and operating the camera, set the camera address, baud rate and video output format etc through DIP switches. The camera has two 8-digit DIP switches: SW1 and SW2 as below:

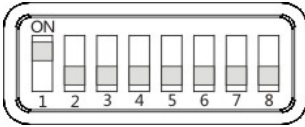

Note

SW1 is used to set address, and mounting type, SW2 is used to set protocol, baud rate and video output format.

Default Settings	
Address	1
Baud Rate	9600bps
Protocol	VISCA
Video Format	1080P25
Mounting Type	Desktop Installation

SW1 settings

No 1~6 are used to set camera address, the DIPs adopt binary system. No. 8 is used to set mounting type. Refer to page 36 for details.

SW2 settings

No. 1 and 2 of SW2 is used to set protocol; no. 3 and 4 is used to set baud rate; No. 5, 6, 7, 8 is used to set video output format. Refer to below chart for details:

SW2					
DIP No.	1	2			
Protocol	OFF	OFF	VISCA		
	ON	OFF	PELCO- D		
	OFF	ON	PELCO- P		
	ON	ON	Reserved		
DIP No.	3	4			
Baud Rate(bps)	OFF	OFF	2400		
	ON	OFF	4800		
	OFF	ON	9600		
	ON	ON	38400		
DIP No.	5	6	7	8	
Video Format	OFF	OFF	OFF	OFF	1080P60
	ON	OFF	OFF	OFF	1080P50
	OFF	ON	OFF	OFF	1080I60
	ON	ON	OFF	OFF	1080I50
	OFF	OFF	ON	OFF	720P60
	ON	OFF	ON	OFF	720P50
	OFF	ON	ON	OFF	1080P30
	ON	ON	ON	OFF	1080P25

When No.5~8 is all ON, camera address, protocol, baud rate, video format and mounting type can be programmed by OSD menu. Please refer to page18 for details of changing video formats through special presets.

Note

PTZ reboot is necessary for the new setting to take effect.

Remote Controller

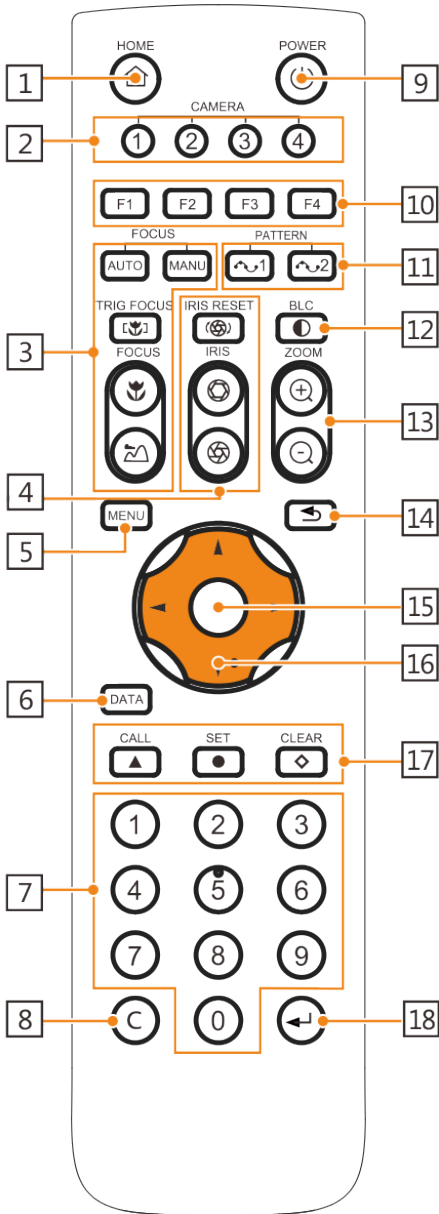

1 HOME

Press **HOME** button, camera moves to initial position.

2 Camera Selection Button

Used to switch among 4 cameras, press 1-4 number buttons to control cameras with 1-4 addresses respectively. For example, press button 1 to control the camera with address 1.

3 Focus



Press "AUTO" button to switch to Auto Focus, press "MANU" button to switch to Manual Focus mode.

"" button to Focus Near

"" button to Focus Far

"" button to Auto Focus once every time it is pressed, then switch back to Manual Focus mode.

4 Iris

Press "" button to reset iris (image brightness) value to default. "" button to Iris Open (brighter image)

"" button to Iris Close (darker image).

5 Menu

Press **MENU** button to enter / exit menu.

6 Data

Reserved.

7 Number Keys

Used to input numbers, for example, preset number.

8 Cancel

To cancel numbers input

9 Power

After the camera has been connected to power source, in none-menu status, press this button to turn on / off the camera.

10 Reserved buttons (F1, F2, F3, F4)

These buttons are reserved for future use.

11 Pattern

Reserved

12 BLC

Used to open / close back light compensation.

13 Zoom

Used to adjust zooming times.

“” button to zoom in

“” button to zoom out.

14 Back

Press “” button to go back to previous menu.





15 OK

In None-menu status: press this button to switch among pan / tilt control speeds.

In Menu status: get into relative menu option after it has been selected.

16 Direction / Menu Operation

In None-menu status, press these four buttons to pan left/right and tilt up/down.

In Menu status:  or  button to select among menu options,  or  to change option / value.

17 Preset Setting

“” button to call a preset.

Input number key(s), and then press this button to call a preset.

“” button to set a preset.

Move the camera to a specific position, adjust focus value and etc, and then press this button to set a preset.

“” button to clear a preset.

Input number key(s), and then press this button to clear a preset.

18 Enter

After inputting numbers, press this button to confirm.

INSTALLATION

The camera has 3 installation types: desktop, ceiling, wall mount installations.

Note

Before installing, make sure there is enough space to install the camera and its parts.

Make sure the installed place is strong and safe enough to hold the camera and relative parts, it is suggested that the installed place can withstand 4 times the weight of the camera and its relative parts.

Desktop Mount Installation

1. Put the camera on a flat surface. In case the camera has to be placed on an inclined surface, make sure the cline angle is less than 15 degrees to ensure proper pan /tilt operation.

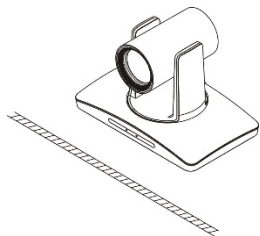

Note

- Take effective measures to avoid camera from dropping.
- Do not grab the camera head when carrying.
- Do not rotate the camera head with hand. It may cause malfunction to the camera.

Wall Mount Installation

(Wall Bracket Supplied Separately)

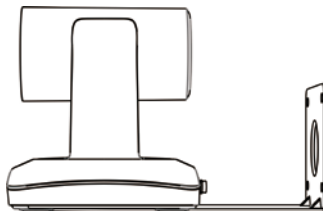

1. According to diameter and position of the 4 installation holes (As shown below) on the bracket, drill 4 holes on the wall and fix the bracket onto the wall by using 4 screws which should be prepared by you.

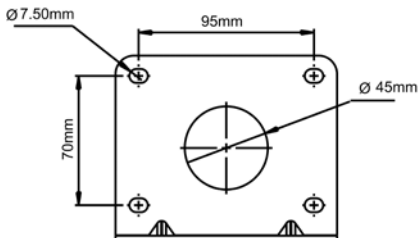

2. Before fixing the camera, set the DIP switches of the camera correctly.

- Use inch screws to fix the camera on the bracket, fix the limit screw according to actual requirement, and make sure the camera is tightly fixed onto the bracket before your hands leave the camera.

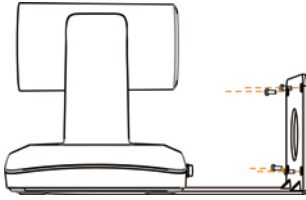

- Fix the mounting plate onto the ceiling or cement roof with 4 screws which should be prepared by you.

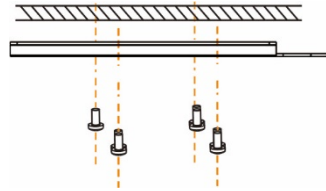

- Before fixing the camera, set the DIP switches of the camera correctly.
- Use 1 screws to fix the camera on the ceiling mount plate.

Ceiling Mount Installation

Ceiling Plates Supplied Separately

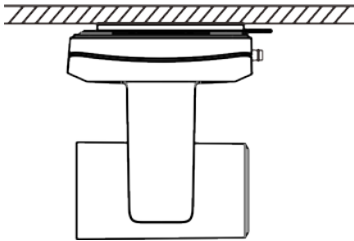

- According to diameter and position of the 4 installation hole (as shown below), drill 4 holes on the ceiling or cement roof correspondingly.

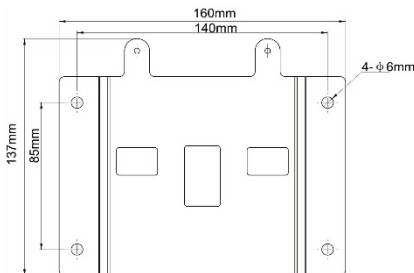

- Push forward camera's bottom slide according to the mounting plate's bottom slide until they reach their limit. Fix the ceiling mount plate and camera's bottom plate with M3×8 screws.

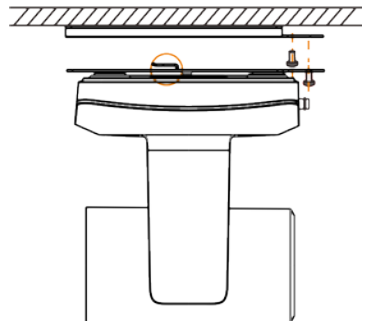

CONNECTIONS

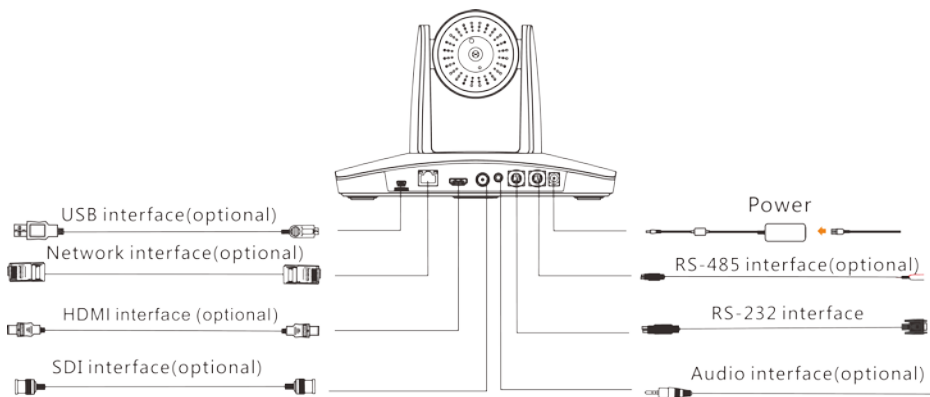

Note

If preset 0 has been saved, after powered on, camera moves to preset 0 automatically; if preset 0 has not been saved, after powered on, camera moves to Home position, where both pan and tilt angle is zero and zooming time is 1x.

MENU SETTINGS

Menu Configuration

<VIDEO>	SHARPNESS	0, 1, 2, 3, 4, 5, 6, 7, 8, 9, 10, 11, 12, 13, 14, 15
Refer to Page 15	BRIGHTNESS	0, 1, 2, 3, 4, 5, 6, 7, 8, 9, 10, 11, 12, 13, 14
	CONTRAST	0, 1, 2, 3, 4, 5, 6, 7, 8, 9, 10, 11, 12, 13, 14
	GAMMA MODE	0, 1, 2, 3, 4
	2DNR LEVEL	1, 2, 3, 4, 5, OFF
	3DNR LEVEL	1, 2, 3, 4, 5, OFF
	WIDE DYNAMIC	1, 2, 3, 4, 5, OFF

<EXPOSURE>
Refer to Page
15

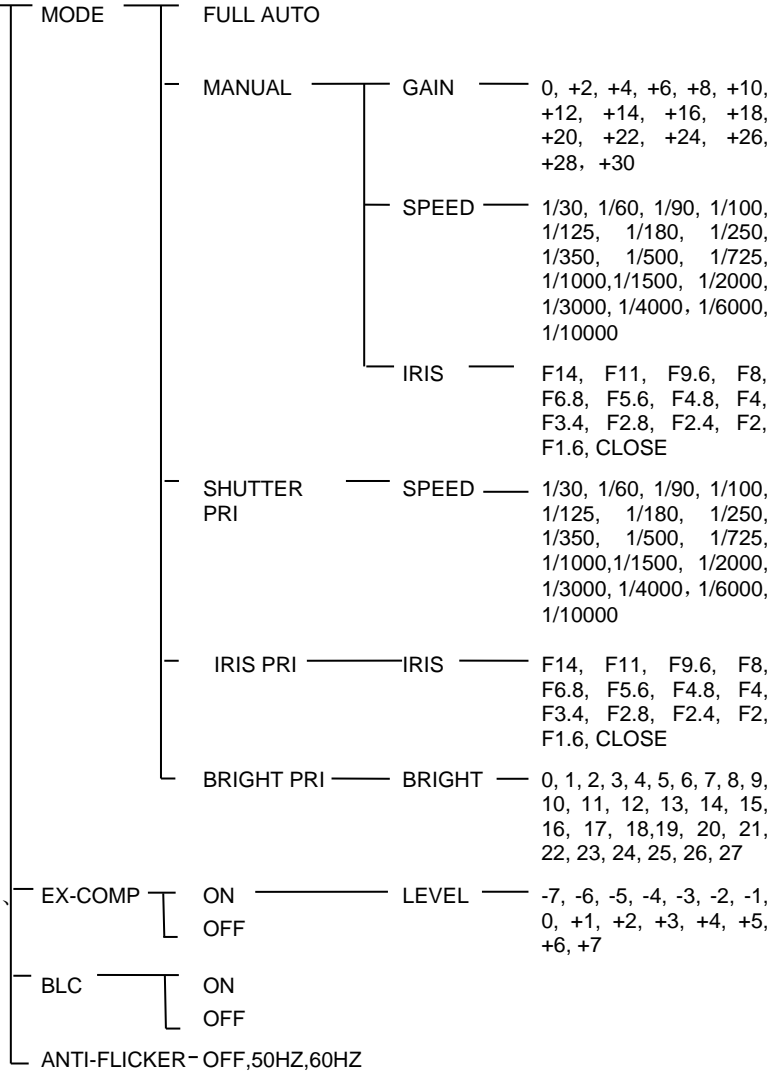

<COLOR> Refer to Page 16	WB MODE	—	AUTO, ATW, ONE PUSH, INDOOR, OUTDOOR, MANUAL, SODIUM LAMP, FLUO LAMP
	SATURATION	—	0, 1, 2, 3, 4, 5, 6, 7, 8, 9, 10, 11, 12, 13, 14
	HUE	—	0, 1, 2, 3, 4, 5, 6, 7, 8, 9, 10, 11, 12, 13, 14

<PAN TILT ZOOM> Refer to Page 17	PAN/TILT SPEED	—	1, 2, 3, 4, 5, 6, 7, 8
	D-ZOOM LIMIT	—	X1, X2, X3, X4, X5, X6, X7, X8, X9, X10, X11, X12
	PTZ TRIG AF	—	ON, OFF
	RATIO SPEED	—	ON, OFF
	POWER UP ACTION	—	PRESET 1, PRESET 2, PRESET 3, PRESET 4, PRESET 5, PRESET 6, PRESET 7, PRESET 8, PRESET 9, HOME

< SYSTEM > Refer to Page 17	ADDRESS	—	1, 2, 3, 4, 5, 6, 7
	PROTOCOL	—	VISCA, PELCO-P, PELCO-D
	BAUDRATE	—	2400, 4800, 9600, 38400
	IR ADDRESS	—	1,2,3,4
	VIDEO FORMAT	—	1080P60, 1080P50, 1080I60, 1080I50, 1080P30, 1080P25, 720P60, 720P50
	MOUNT MODE	—	STAND, CEILING
	RS485 PORT	—	HALF-DUPLEX-1, HALF-DUPLEX-2
	LANGUAGE	—	ENGLISH

<STATUS> ——— ADDRESS ——— 1
Refer to Page 18 ——— PROTOCOL ——— VISCA
————— BAUD RATE ——— 9600
————— IR ADDRESS ——— 1
————— VIDEO FORMAT ——— 1080P25
————— MOUNT MODE ——— STAND
————— FIRMWARE VER ——— 1.0.06

<RESTORE DEFAULTS> Refer to Page18

Menu Explanation

Main Menu

Main Menu Call Preset #95 to enter menu.

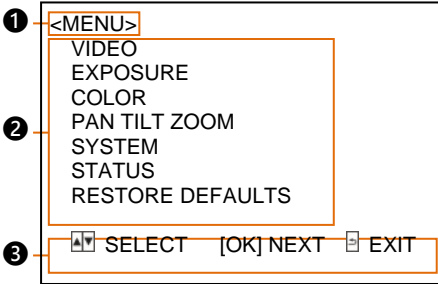

1 Menu Title

It displays currently selected menu option

2 Menu Options

It displays options under current menu title.
Click UP or DOWN button to select among menu options, once color of options turned to different color, it indicates the menu has been elected, click IRIS+ button to get into this menu.

Submenus

From main menu, navigate to select

<EXPOSURE> menu, click IRIS+ to enter.

<EXPOSURE>Set menu.

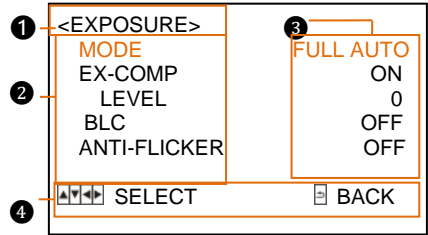

1 2 Please refer to the same controls to the Main Menu

3 Menu options

Click ◀ or ▶ to change the values.

Video

VIDEO menu is used to change video value.

<VIDEO>	
SHARPNESS	8
BRIGHTNESS	7
CONTRAST	2
GAMMA MODE	0
2DNR LEVEL	OFF
3DNR LEVEL	OFF
WIDE DYNAMIC	OFF
SELECT	BACK

Available Options:

SHARPNESS: 0, 1, 2, 3, 4, 5, 6, 7, 8, 9, 10, 11, 12, 13, 14, 15.

BRIGHTNESS: 1, 2, 3, 4, 5, 6, 7, 8, 9, 10, 11, 12, 13, 14.

CONTRAST: 1, 2, 3, 4, 5, 6, 7, 8, 9, 10, 11, 12, 13, 14.

GAMMA MODE: 0, 1, 2, 3, 4.

2DNR LEVEL: 1, 2, 3, 4, 5, OFF

3DNR LEVEL: 1, 2, 3, 4, 5, OFF.

WIDE DYNAMIC: 1, 2, 3, 4, 5, OFF.

Exposure

EXPOSURE menu is used to adjust exposure value.

<EXPOSURE>	
MODE	FULL AUTO
EXP-COMP LEVEL	ON 0
BLC	ON
ANTI-FLICKER	OFF
SELECT	BACK

MODE:

FULL AUTO: Gain, Shutter Speed and Iris value are adjusted automatically accordingly to working environment.

MANUAL: manually adjust Gain, Shutter Speed and Iris

GAIN: 0, +2, +4, +6, +8, +10, +12, +14, +16, +18, +20, +22, +24, +26, +28, +29, +30.

SPEED: 1/30, 1/60, 1/90, 1/100, 1/125, 1/180, 1/250, 1/350, 1/500, 1/725, 1/1000, 1/1500, 1/2000, 1/3000, 1/4000, 1/6000, 1/10000.

IRIS: F14, F11, F9.6, F8, F6.8, F5.6, F4.8, F4, F3.4, F2.8, F2.4, F2, F1.6, CLOSE.

SHUTTER PRI: Gain and Iris value are adjusted automatically according to working environment; shutter speed value is adjustable manually.

SPEED: 1/30, 1/60, 1/90, 1/100, 1/125, 1/180, 1/250, 1/350, 1/500, 1/725, 1/1000,

1/1500, 1/2000, 1/3000, 1/4000, 1/6000,
1/10000.

IRIS PRI: Gain and shutter speed value are adjusted automatically according to working environment; Iris value is adjustable manually.

IRIS: F14, F11, F9.6, F8, F6.8, F5.6, F4.8,
F4, F3.4, F2.8, F2.4, F2, F1.6, CLOSE.

BRIGHT PRI: Manually adjust the video brightness.

BRIGHT: 0, 1, 2, 3, 4, 5, 6, 7, 8, 9, 10, 11, 12,
13, 14, 15, 16, 17, 18, 19, 20, 21, 22, 23, 24,
25, 26, 27.

EXP-COMP: Once EXP-COMP is set as On, below level options become available -7, -6, -5, -4, -3, -2, -1, 0, +1, +2, +3, +4, +5, +6, +7
+7 is the maximum compensation value for bright, -7 is the maximum compensation value for dark.



BLC: ON, OFF.

Backlight compensation (BLC) is video gain done automatically to correct the exposure of subjects that are in front of a bright light source.

ANTI-FLICKER (OFF, 50Hz, 60Hz): To avoid video flicker at power systems of different frequency.

COLOR

COLOR menu is used to adjust color related values. Available options:

< COLOR >	
WB MODE	MANUAL
R.GAIN	7
B.GAIN	7
SATURATION	7
HUE	7
 SELECT	 BACK

WB MODE: AUTO, ATW (auto tracking), ONE PUSH, INDOOR, OUTDOOR, MANUAL, SODIUM LAMP, FLUO LAMP

“ONE PUSH”: In “ONE PUSH TRIGGER” mode, aim the camera at a pure white object (say a white paper), then press  button.

“AUTO” mode: R.GAIN, G.GAIN and B.Gain can be chosen from -7~+7.



“MANUAL” mode: R.GAIN and B. GAIN value can be chosen from 0~255.

SATURATION: 0, 1, 2, 3, 4, 5, 6, 7, 8, 9, 10, 11, 12, 13, 14.

HUE: 0, 1, 2, 3, 4, 5, 6, 7, 8, 9, 10, 11, 12, 13, 14.

Pan/Tilt/Zoom

PAN/TILT/ZOOM is used to change pan/tilt/zoom value, available options:

<PAN TILT ZOOM>	
PAN/TILT SPEED	8
D-ZOOM LIMIT	X1
PTZ TRIG AF	ON
RATIO SPEED	ON
POWER UP ACTION	HOME
  SELECT	 BACK

PAN/TILT SPEED: 1, 2, 3, 4, 5, 6, 7, 8 the bigger the number is, the faster the speed is.



D-ZOOM LIMIT: X1, X2, X3, X4, X5, X6, X7, X8, X9, X10, X11, X12.

PTZ TRIG AF: Turn ON / OFF the auto focus when the camera pans / tilts / zooms.

RATIO SPEED (ON, OFF): Set the relation of PT speed as per zoom time. When it's on, PTZ speed will be faster when zoom time is bigger.

POWER UP ACTION: PRESET 1, PRESET 2, PRESET 3, PRESET 4, PRESET 5, PRESET 6, PRESET 7, PRESET 8, PRESET 9, HOME.

System

<SYSTEM>	
ADDRESS	1
PROTOCOL	VISCA
BAUD RATE	9600
IR ADDRESS	1
VIDEO FORMAT	1080P25
MOUNT MODE	STAND
RS485 PORT	HALF-DUPLEX-1
LANGUAGE	ENGLISH
  SELECT	 BACK

ADDRESS: 1, 2, 3, 4, 5, 6, 7.

PROTOCOL: VISCA, PELCO-D, PELCO-P;

BAUD RATE: 2400, 4800, 9600, 38400;

IR ADDRESS: 1,2,3,4, set camera address to be controlled by remote controller.

VIDEO FORMAT: 1080P60, 1080P50, 1080P30, 1080P25, 1080I60, 1080I50, 720P60, 720P50;

MOUNT MODE: STAND, CEILING;

RS485 PORT:

HALF-DUPLEX-1: the camera will not return ACK/FINISH/FAULT msg.

HALF-DUPLEX-2: the camera will return ACK/FINISH/FAULT msg.

LANGUAGE: ENGLISH

STATUS

```
< STATUS>
ADDRESS          1
PROTOCOL         VISCA
BAUD RATE        9600
IR ADDRESS       1
VIDEO FORMAT     1080P25
MOUNT MODE       STAND
FIRMWARE VER     V3.1.02
```

 BACK



Display information (address, protocol, baud rate, IR address, video format, mount mode, image version and firmware version) of the current camera.

Restore Defaults

```
< RESTORE DEFAULTS>
PRESS OK        CONFIRM
PRESS BACK      CANCEL
```

 BACK

RESTORE DEFAULTS option is used to reset all menus to default value.

Press  to confirm or press  to cancel and return to previous menu.

List of Special Preset Commands

Preset No.	Function
95	Get into menu
96	Delete all presets
99	Reboot the PTZ
100	Video format: 1920X1080P50
101	Video format: 1920X1080P25
102	Video format: 1920X1080I50
103	Video format: 1280X720P50
105	Video format: 1920X1080P60
106	Video format: 1920X1080P30
107	Video format: 1920X1080I60
108	Video format: 1280X720P60

Network Connection

Connect the camera to network with an Ethernet cable, power on the camera.

LAN Connection

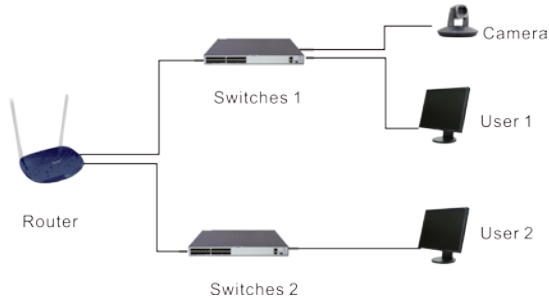

Please refer to the above diagram, user1 and user 2 are in the same router, they are considered as in the same LAN, connect the camera to the same LAN as where the PC is, and refer to below instructions as how to use the application software, then the camera can be found and connected from the online device list.

WAN Connection

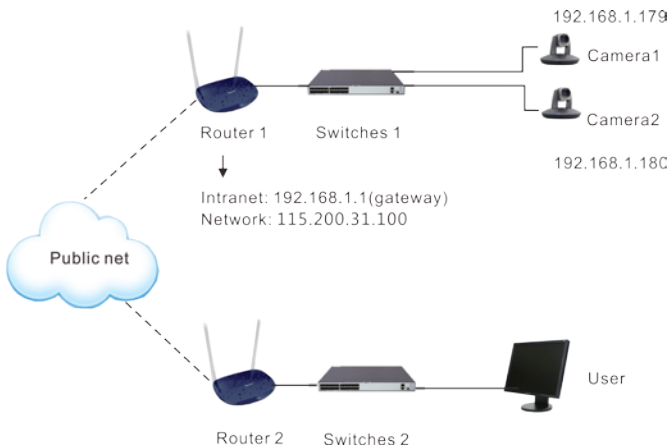

Please refer to the above diagram, user and the camera are in different routers, they are considered as in a WAN; in this condition, application software iSmartCMS can not search and find the camera automatically. User can still connect after below conditions are satisfied: (1) Set camera's IP address as static IP address (2) Router of the LAN where camera is connected supports Port Mapping. (3) Router of the LAN where camera is connected has fixed public IP address. Follow below steps to connect:

Step One

Set camera's IP address in LAN: connect user PC to the LAN (Router 1) where the camera is connected according to LAN connection instructions, use application software iSmartCMS to search and find the camera, then add it to manage; then set camera's IP address in the same network segment as the router 1. Camera's gateway is usually set at Router 1's LAN IP address, for example, 192.168.1.1, then camera's IP address can be set as for example 192.168.1.179 or 192.168.1.180 as long as they are in the same network segment.

Steps Two

Route Mapping: User PC logs into router configuration menu, gets into "Port Mapping" (router management authorization may be required); refer to below picture, DO NOT tick "Do not apply this rule", from first frame under "External port", input any number from 1~65535, but preferred to be set at more than 10000 like 10200 so there will be less port conflict possibility. From "Internal IP", input the camera's IP address 192.168.1.179, from first frame of "Internal Port", input 3478, (all cameras use this same port number). "Protocol" and "Mapping Line" can be default, from "Note", input "Camera 1's mapping port" or something to understand.

Port mapping

List of rules

<input type="checkbox"/> Do not apply this rule	If you disable this rule, the following configuration will only be saved but will not be applied.
Not applied	
External port	<input type="text"/> <input type="text"/> You can input an external port or an external port segment to be mapped to an open port or port segment of an internal host. If you leave it blank, the external port or port segment is identical to the internal port or port segment. The range is between 1 and 65535.
Internal IP	<input type="text"/> The IP address of the internal host that provides external service. For example: <i>192.168.0.50</i>
Internal port	<input type="text"/> <input type="text"/> The open port or port segment of the internal host that provides external services. The range is between 1 and 65535.
Protocol	TCP ▾ The protocol used for port mapping can be TCP, UDP or both.
Mapping line	Any ▾ The line used for port mapping can be single WAN or multi WAN.
Note	<input type="text"/> You can write a short note to describe this mapping rule. For example: <i>The WEB server for Marketing Department.</i>

Save

Back

Help

Port mapping function can map the service port of the intranet server host to extranet, so external network users can access the services offered by the intranet server through the external IP address and port of the router.

Notice:
- Port mapping works only if "Block extranet requests" on the Attack defense page is disabled.

Step Three

Access from external network: Router 1's public IP address is 115.200.31.100, for example, go through the above steps one and two, WAN users under router 2 can access camera 1 through IP address 115.200.31.100 + port 10200. Then, in WAN, the mapping of camera 1 and (IP 115.200.31.100 + port 10200) is established. Camera 2 can use another external port such as 10320, so mapping of camera 2 with (IP 115.200.31.100 + port 10320) is established. In the "Managed Device" of the client software iSmart CMS, click "+ Add", enter the IP address 115.200.31.100 and port 10200 and other information, then the camera 1 can be accessed and controlled.

Client Software Instruction

Search and list the camera

Install and open the client software in PC, enter the main interface:

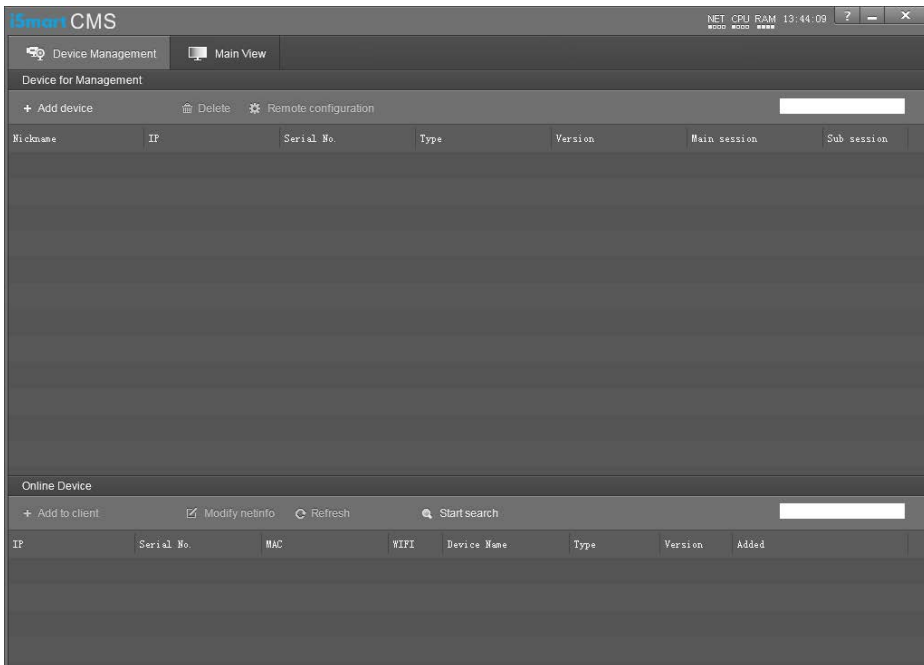

If the camera and PC are in the same LAN, click “Start Search”, then searching starts and all online devices will be listed, as the picture shown below:

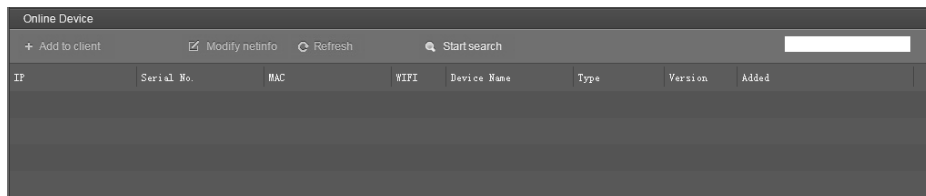

To modify the device IP address, input the IP address, mask, gateway in the “Modify Network” column.

✕
Modify Network Parameter

Ethernet

Device information:

CameraName:

Mac:

SN:

Network information:

ConnType:

IP:

Mask:

Gateway:

DNS1:

DNS2:

To control and preview a camera, first choose the device, modify its IP address as the IP address of the same LAN, then click "Add to Client" as the picture shown below.

Online Device							
+ Add to client <input checked="" type="checkbox"/> Modify netinfo <input type="button" value="Refresh"/> Stop search							
IP	Serial No.	MAC	WiFi	Device Name	Type	Version	Added
10.0.3.128	L6D3V3H2B9OUQIK4G224	00:04:05:01:88:89	No	av200_4K	LZC5-FT9M	1.0.00	
10.0.3.212	8C8863H2BYOUQIK4515XZ	00:04:05:01:88:7E	No	e200t-rdttt	E200T	2.0.00	
10.0.3.240	S007G5H2BYOSQW241W0	00:04:05:01:88:36	No	S007G5H2BYOSQW241W0	LTC	5.0.04	

Please check that all IP addresses are in the same LAN.

Remote Configuration

Choose the camera in the device list, click "Remote Configuration" in the column to upgrade or config the camera.

Upgrade

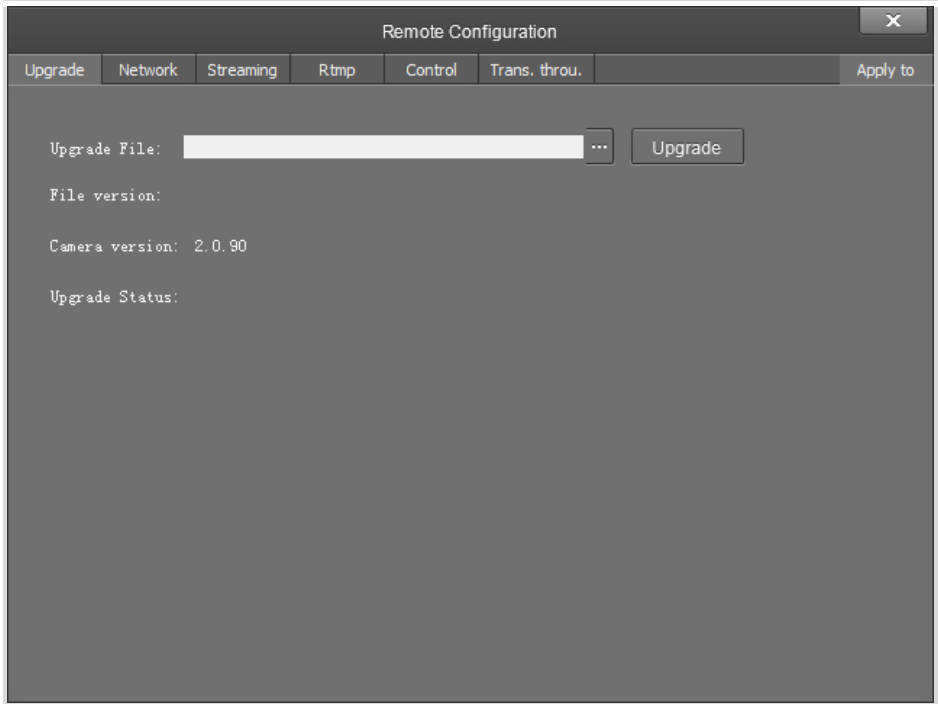

Click "Upgrade" menu to enter the main interface, as the picture shown above.

Click to search and load the updating firmware, then click "Upgrade" to start upgrading. Do not power off the camera during upgrading. After upgrading is completed, camera will reboot.

Network

The screenshot shows a 'Remote Configuration' dialog box with a 'Network' tab selected. The dialog has a title bar with a close button (X) and a tab bar with options: Upgrade, Network, Streaming, Rtmp, Control, Trans. throu., and Apply to. The main area contains the following fields:

Connect with	Static IP	rtsp port	554
IP Address	10.0.3.146	app port	5000
Mask	255.255.255.0		
Gateway	10.0.3.1		
DNS 1	10.0.0.1		
DNS 2	0.0.0.0		

A 'Save' button is located at the bottom right of the dialog.

- Connect with: please choose from Static IP or dynamic IP address;
- IP address: input IP address for the camera;
- Mask: input mask address for the camera;
- Gateway: input gateway IP address;
- DNS 1: server-prior, input DNS address for the device;
- DNS 2: It will be used in case DNS1 server is not working;
- Port: streaming port(RTSP) and application port(SDK connection) can be configured. The range of stream ports is 3479~7999 and 554, default is 554. The range of application ports is 3479~7999, default is 5002;
- Click the "Save" button after setting is completed;
- Camera will connect to ethernet after above-mentioned operations;

Streaming

Remote Configuration ✕

Upgrade Network **Streaming** Rtmp Control Trans. throu. Apply to

Stream type	Main stream	Channels	MORO
Resolution	1080P	Encode type	AAC
Video rate type	CBR	Sample rate	16KHz
Max rate (Kbps)	4096	Audio rate	64Kbps
Frame rate	fullfps	Input pin	LineIn
Key frame interval	25	Volume	<input type="range" value="50"/>
Video coding type	H264		<input type="button" value="Save"/>
Encode Level	High		

- Stream type: set the parameters of main stream, sub stream, third stream, fourth stream.
- Resolution: set among 4K(3840*2160), 1080P(1920*1080), 720P(1280*720), D1&QVGA(320*240), choose resolutions based on actual requirements and capability of device. The higher the resolution is, the better network requirements will be needed.
- Max rate: configure max stream rate or adjustable stream rate.
- Frame rate: choose from different frame per second
- Key frame interval: configure the number of frames between the two key frames. The larger the key frame interval is, the smaller the fluctuation of the byte will be, but the image quality is relatively poor. Vice versa, the larger the fluctuation of the byte will be, the higher the image quality will be.
- Video coding type: choose H.264 or H.265.
- Encode level: choose from Base, Main and High.

RTMP

Remote Configuration ✕

Upgrade Network Streaming **Rtmp** Control Trans. throu. Apply to

RTMP 1	<input type="checkbox"/>	Main stre:	rtmp://10.0.3.6:31935/live/lrc5
RTMP 2	<input type="checkbox"/>	Sub strear	rtmp://10.0.3.6:31935/live/lrc6
RTMP 3	<input type="checkbox"/>	Main stre:	qulubo://dev.opensight.cn:5000/?c=JG0001812120
RTMP 4	<input type="checkbox"/>	Sub strear	rtmp://10.0.3.6:31935/live/lrc6

Save

In RTMP1 and RTMP2, main stream, sub stream, third stream, fourth stream can be chosen to stream.

Control

- Password setting: when a password is required, the camera can be accessed only after a correct password is input.
- Reboot: reboot the camera.

The screenshot shows the 'Remote Configuration' window with the 'Control' tab selected. The window has a title bar with a close button (X) and a navigation bar with tabs for 'Upgrade', 'Network', 'Streaming', 'Rtmp', 'Control', 'Trans. throu.', and 'Apply to'. The 'Control' tab is active. The interface is divided into two columns. The left column contains password and reboot settings, while the right column contains time and NTP settings.

Field	Value	Action
Old password	[Redacted]	
New password	[Redacted]	
Confirm	[Redacted]	
Save	[Save]	
Reboot	[Reboot]	
Device name	LZC5-F79N	[Save]
Local Time	2018-12-17 14:24:28	[OK]
Show Time	<input checked="" type="checkbox"/>	
Time Format	YYYY-MM-DD HH:mm:ss	[OK]
Refresh NTP	<input checked="" type="checkbox"/>	
TimeZone	-07:00	
NTP Server	202.120.2.101	[OK]

Transparent Transmission

The screenshot shows a 'Remote Configuration' dialog box with a close button (X) in the top right corner. Below the title bar is a tabbed interface with the following tabs: 'Upgrade', 'Network', 'Streaming', 'Rtmp', 'Control', 'Trans. throu.', and 'Apply to'. The 'Trans. throu.' tab is currently selected. The configuration area contains the following fields:

- Enable:** A dropdown menu with 'Disable' selected.
- Protocol:** A dropdown menu with 'TCP' selected.
- Camera as:** A dropdown menu with 'Client' selected.
- IP:** A text input field containing '0.0.0.0'.
- Port:** A text input field containing '0'.

At the bottom of the configuration area is a 'Save' button.

- Enable / Disable: enable / disable transparent transmission;
- Protocol: choose TCP or UDP protocols;
- Camera as: choose Client or Server;
- IP: when the camera is set as client, the IP address of the transmitted camera is needed. When the camera is set as server, the IP address can be left as black;
- Port: choose from 1-65535 as transparent transmission port.

Preview

Click “Main View” to get into camera control and preview part as below.

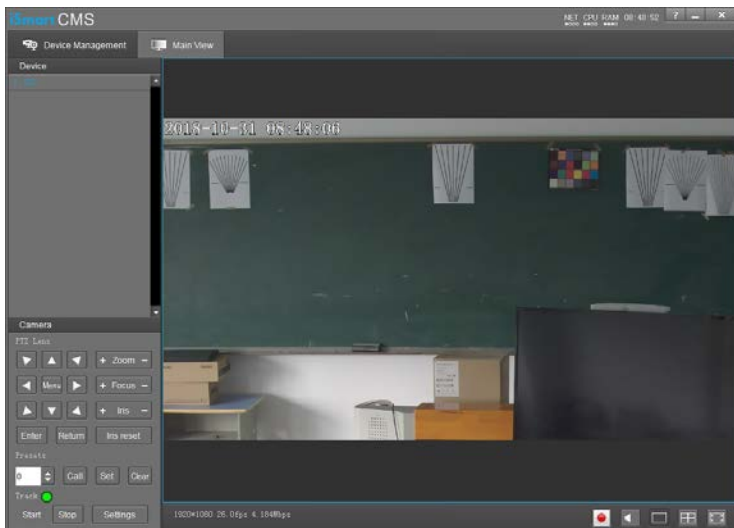
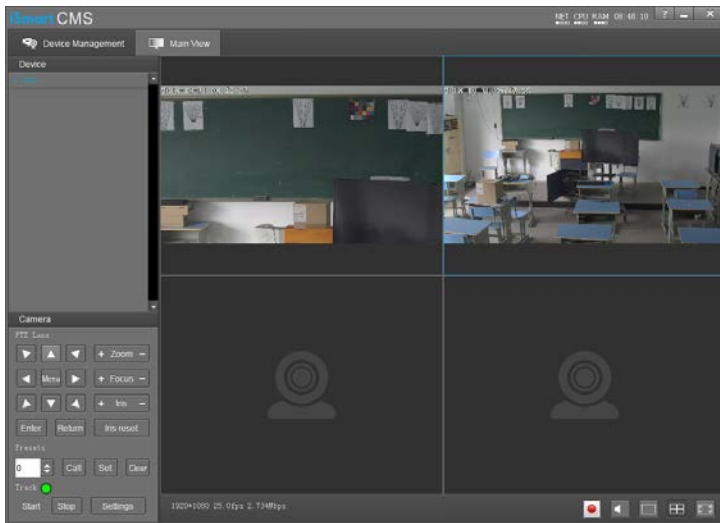

This interface includes three main parts: Device List, Device Control, Video Preview

- Device: It displays all online cameras added to “Device Management”.

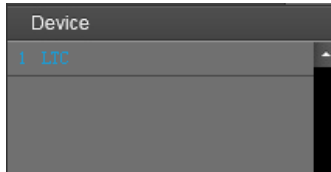

- Device Control: get control of the selected camera (camera name in blue).

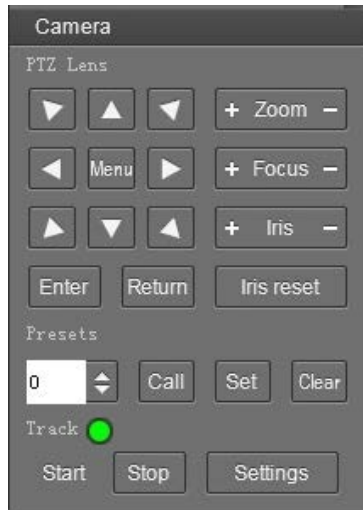

- Video Preview: double click the camera in the list, main camera stream will be displayed in the preview window; or right click the selected camera from the left column to get its main or substream video. Video preview mode can be single video or four video's, when in four video's mode, select one of the four video's then choose the bottom right icon to enlarge this selected video to a big single window.

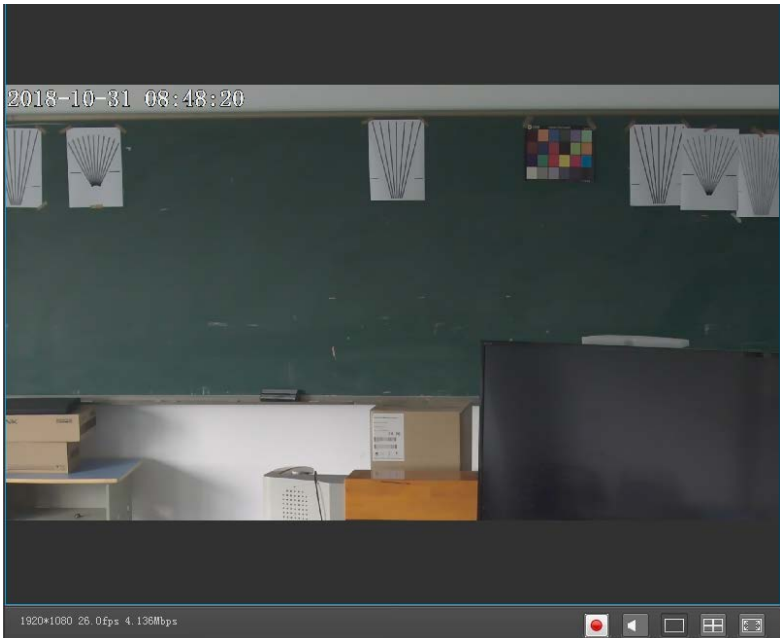
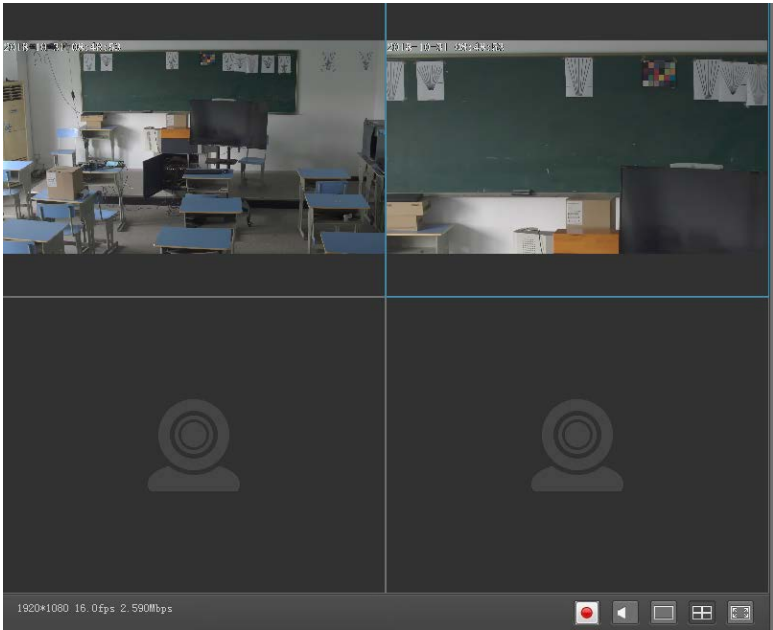

ANNEX 1 TECHNICAL SPECIFICATIONS

Items	Value	
Image Sensor	1/2.8" CMOS, 2.14 megapixel	
Focal Lens	f=4.7~94.0mm	f=3.9mm-46.8mm
Iris	F1.6 – F3.5	F1.6-F2.8
Optical Zoom	20x	12x
Digital Zoom	12x	
Horizontal Viewing Angle	59.5° -2.9°	72.5° -6.3°
Focus System	Auto, Manual, PTZ Trigger, One Push Trigger	
Exposure Control	Auto, Manual, Shutter Priority, Iris Priority, Smart	
Min. Illumination	0.5lux(color), 0.1lux(B/W)	
Shutter Speed	1/1 to 1/10,000s	
Gain	Auto /Manual	
White Balance	Auto, Indoor, Outdoor, One Push, Manual, Auto Tracking, Sodium Lamp, Fluo Lamp	
Wide Dynamic	Yes	
Back Light Compensation	Yes	
Digital Noise Reduction	2D/3D	
S/N	≥50dB	
Function		
Pan Angle	-170°~+170°	
Tilt Angle	-30°~+90°	
Pan Speed	0.1°~120°/S	
Tilt Speed	0.1°~80°/S	
Preset Number	256	
OSD	Yes	
Image Flip	Yes	
SDI Output		
Video Format	1080P60, 1080I60, 1080P30, 720P60 1080P50, 1080I50, 1080P25, 720P50	
NETWORK		
Resolution	Max Support 1920*1080@60fps	
Image Compression	H.265, H.264	
Audio Compression	AAC	
Protocols	ONVIF, RTSP, RTMP, HTTP, TCP, UDP	
Dual Stream	Support	
Interface		
Video Output	1 channel 3G-SDI, 1 channel HDMI	
Audio	1 channel LINE IN, 1 channel LINE OUT	
Network Interface	RJ45 (10M/100M) interface, Optional POE (Power over Ethernet)	
Local Storage	TF card, max 64G	
Control Interface	1 channel RS-485, 1 channel RS-232 IN, 1 channel RS-323 OUT	

IR Throughout Output	1 channel IR throughout output
General	
Protocols	VISCA (support daisy chain) / PELCO-P / PELCO-D
Address	0-63
Power	DC12V
Power Consumption	<20W
Operating Temperature	0°C~+40°C
Storage Temperature	-20°C~+60°C
Dimensions (WxHxD)	243mm×145mm×163mm
Weight	1.2KG
Body color	grey

ANNEX 2 SIZE AND DIMENSION

Front

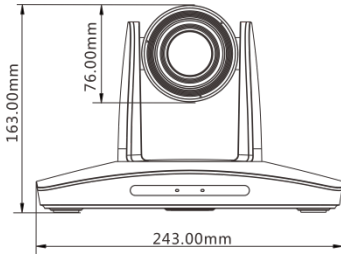

Rear

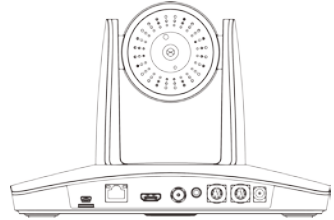

Top

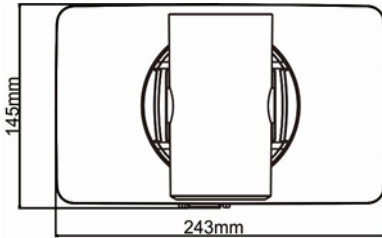

Side

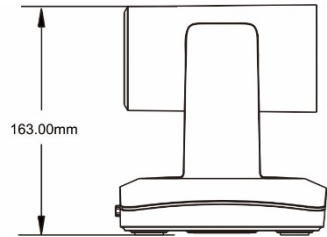

Bottom

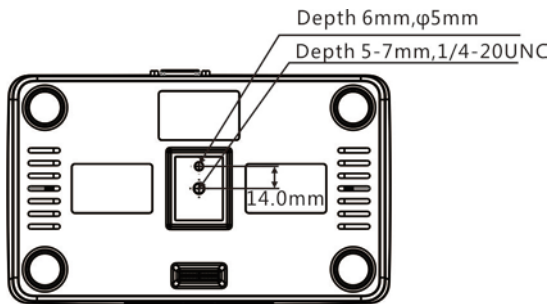

ANNEX 3 SW1 DEFINITION

DIP No. Address	1	2	3	4	5	6
0	OFF	OFF	OFF	OFF	OFF	OFF
1	ON	OFF	OFF	OFF	OFF	OFF
2	OFF	ON	OFF	OFF	OFF	OFF
3	ON	ON	OFF	OFF	OFF	OFF
4	OFF	OFF	ON	OFF	OFF	OFF
5	ON	OFF	ON	OFF	OFF	OFF
6	OFF	ON	ON	OFF	OFF	OFF
7	ON	ON	ON	OFF	OFF	OFF
8	OFF	OFF	OFF	ON	OFF	OFF
9	ON	OFF	OFF	ON	OFF	OFF
10	OFF	ON	OFF	ON	OFF	OFF
11	ON	ON	OFF	ON	OFF	OFF
12	OFF	OFF	ON	ON	OFF	OFF
13	ON	OFF	ON	ON	OFF	OFF
14	OFF	ON	ON	ON	OFF	OFF
15	ON	ON	ON	ON	OFF	OFF
16	OFF	OFF	OFF	OFF	ON	OFF
17	ON	OFF	OFF	OFF	ON	OFF
18	OFF	ON	OFF	OFF	ON	OFF
19	ON	ON	OFF	OFF	ON	OFF
20	OFF	OFF	ON	OFF	ON	OFF
21	ON	OFF	ON	OFF	ON	OFF
22	OFF	ON	ON	OFF	ON	OFF
23	ON	ON	ON	OFF	ON	OFF
24	OFF	OFF	OFF	ON	ON	OFF
25	ON	OFF	OFF	ON	ON	OFF
26	OFF	ON	OFF	ON	ON	OFF
27	ON	ON	OFF	ON	ON	OFF
28	OFF	OFF	ON	ON	ON	OFF
29	ON	OFF	ON	ON	ON	OFF
30	OFF	ON	ON	ON	ON	OFF
31	ON	ON	ON	ON	ON	OFF
32	OFF	OFF	OFF	OFF	OFF	ON
33	ON	OFF	OFF	OFF	OFF	ON
34	OFF	ON	OFF	OFF	OFF	ON
35	ON	ON	OFF	OFF	OFF	ON
36	OFF	OFF	ON	OFF	OFF	ON
37	ON	OFF	ON	OFF	OFF	ON
38	OFF	ON	ON	OFF	OFF	ON
39	ON	ON	ON	OFF	OFF	ON

40	OFF	OFF	OFF	ON	OFF	ON
41	ON	OFF	OFF	ON	OFF	ON
42	OFF	ON	OFF	ON	OFF	ON
43	ON	ON	OFF	ON	OFF	ON
44	OFF	OFF	ON	ON	OFF	ON
45	ON	OFF	ON	ON	OFF	ON
46	OFF	ON	ON	ON	OFF	ON
47	ON	ON	ON	ON	OFF	ON
48	OFF	OFF	OFF	OFF	ON	ON
49	ON	OFF	OFF	OFF	ON	ON
50	OFF	ON	OFF	OFF	ON	ON
51	ON	ON	OFF	OFF	ON	ON
52	OFF	OFF	ON	OFF	ON	ON
53	ON	OFF	ON	OFF	ON	ON
54	OFF	ON	ON	OFF	ON	ON
55	ON	ON	ON	OFF	ON	ON
56	OFF	OFF	OFF	ON	ON	ON
57	ON	OFF	OFF	ON	ON	ON
58	OFF	ON	OFF	ON	ON	ON
59	ON	ON	OFF	ON	ON	ON
60	OFF	OFF	ON	ON	ON	ON
61	ON	OFF	ON	ON	ON	ON
62	OFF	ON	ON	ON	ON	ON
63	ON	ON	ON	ON	ON	ON

DIP No.	7	
Reserved	Reserved	Reserved
DIP No.	8	
Mounting Type	ON	Ceiling
	OFF	Stand

TROUBLESHOOTING

Problem	Possible Cause	Solution
No action or image after powered on	Power supply failure	Check power supply
	Power adapter damaged	Replace power adapter
	Power cable connection got loosen	Check & reconnect
No self-testing after powered on, or with motor noise	Power cable is too long	Use a shorter cable
	Power adapter damaged	Replace power adapter
	Mechanical failure	Repair
Not controllable from remote controller	Low battery of remote controller	Change battery for remote controller
	Exceed remote control distance	Control within distance of 8M
After power on, self-test successfully, but not controllable	Wrong address / protocol / baud rate	Check & set again
	Wrong connection or open circuit of RS-485/RS422 or RS-232 cable	Check & reconnect
Video loss when pans / tilts / zooms	Power cable is too long	Use a shorter cable
	Power adapter damaged	Replace power adapter
	Video cable not properly connected	Replace with a good video cable
Video captured after connected to digital video interface of a capture device is not good as the video captured after connected directly analog video interface of the capture device	Different video capture devices have different video capturing performance, image quality maybe worse after it has been converted from analog to digital	Consult video capture device supplier for more information

The user manual is only for a reference, if there are any changes or differences, please ask for the latest version from your supplier