

FULL HD PTZ CAMERA

User Manual (V1.0)

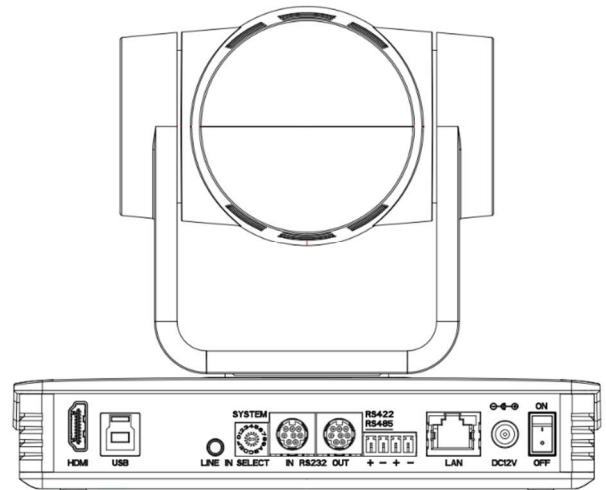

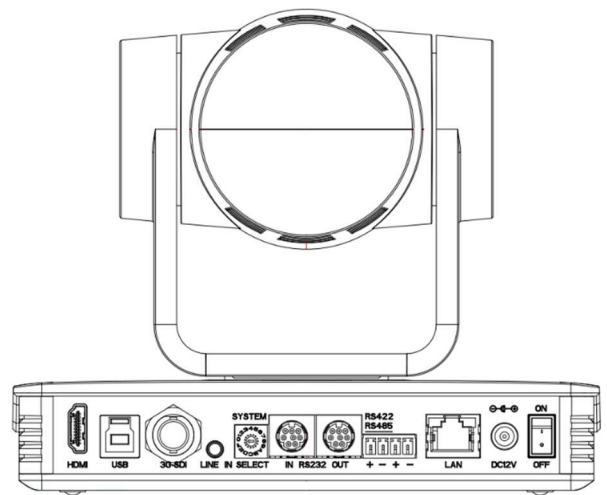
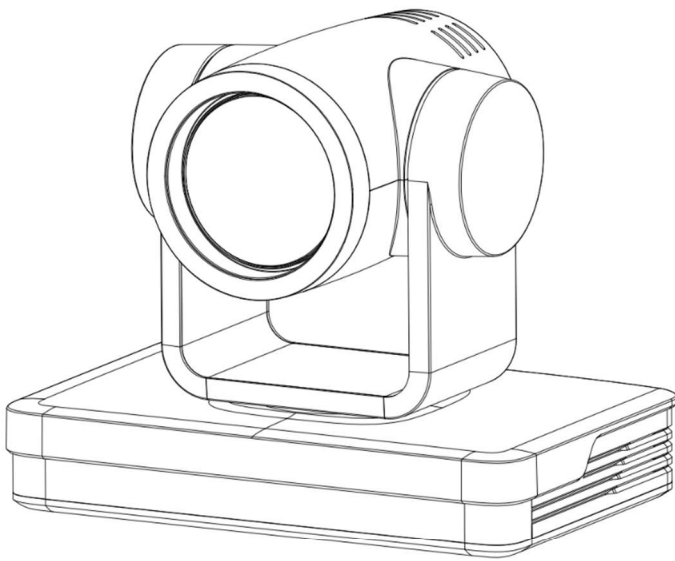

Attentions

Improper operations may damage the product structure and result in mechanical failure.

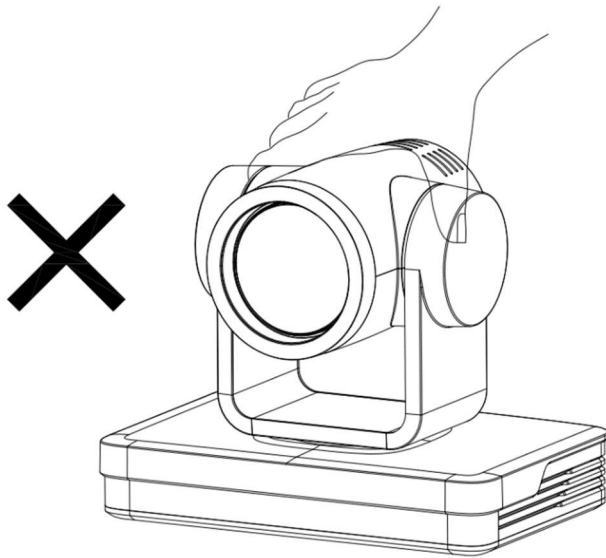
Please note the following tips:



 Do not move the camera by grabbing the head.

 Move the camera by holding the bottom with one or both hands.

 Please do not rotate the lens and holder manually no matter the camera is power on or off; otherwise it may damage the camera structure and result in failure of camera self-check and unable to start the camera

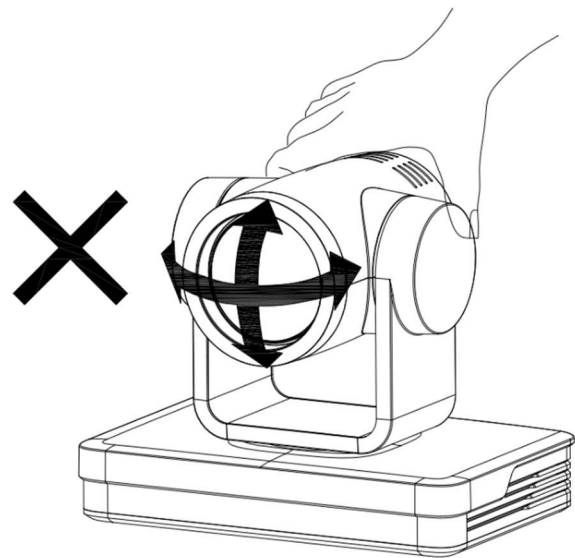

This manual introduces functions, installations and operations for this PTZ camera in details. Please read this manual carefully before installation and use.

1. Cautions

- 1.1 Avoid damage to product caused by heavy pressure, strong vibration or immersion during transportation, storage and installation.
- 1.2 Housing of this product is made of organic materials. Do not expose it to any liquid, gas or solids which may corrode the shell.
- 1.3 Do not expose the product to rain or moisture.
- 1.4 To prevent the risk of electric shock, do not open the case. Installation and maintenance should only be carried out by qualified technicians.
- 1.5 Do not use the product beyond the specified temperature, humidity or power supply specifications.
- 1.6 Wipe it with a soft, dry cloth when cleaning the camera lens. Wipe it gently with a mild detergent if needed. Do not use strong or corrosive detergents to avoid scratching the lens and affecting the image.
- 1.7 This product contains no parts which can be maintained by users themselves. Any damage caused by dismantling the product by user without permission is not covered by warranty.

2. Electrical Safety

Installation and use of this product must strictly comply with local electrical safety standards.

The power supply of the product is $\pm 12V$, the max electrical current is 2A .



3. Install

- 3.1 Do not rotate the camera head violently, otherwise it may cause mechanical failure.
- 3.2 This product should be placed on a stable desktop or other horizontal surface. Do not install the product obliquely, otherwise it may display inclined image.
- 3.3 Ensure there are no obstacles within rotation range of the holder.
- 3.4 Do not power on before completely installation.

4. Magnetic Interference

Electromagnetic fields at specific frequencies may affect the video image. This product is Class A. It may cause radio interference in household application. Appropriate measure is required.

Content

1. Camera Installation.....	4
1.1 Camera Introduction.....	4
1.2 Interfaces and Connection	5
1.3 Mounting Brackets.....	5
2. Product Overview	9
2.1 Model.....	9
2.2 Dimension.....	10
2.3 Accessory.....	10
2.4 RS-232 Interface.....	11
2.5 Rotary DIP Switch.....	12
2.6 Main Features	12
2.7 Technical Parameter.....	13
3. Remote Control.....	15
3.1 Match Code for Wireless Remote Control.....	15
3.2 Keys Introduction for IR Remote Control	16
3.3 Menu Introduction	18
4. Network Configuration.....	20
4.1 Network Connection.....	20
4.2 IE Login.....	21
4.3 Streaming.....	21
4.4 Software Upgrading.....	23
5. Serial port communication and control.....	24
5.1 VISCA Protocol Return Command.....	24
5.2 VISCA Protocol Control Command	25
5.3 VISCA Protocol Inquiry Command.....	27
5.4 Pelco-D protocol command list	29
5.5 Pelco-P protocol command list	30
6. Maintenance and Troubleshooting.....	31
6.1 Maintenance.....	31
6.2 Troubleshooting	31
7. Copyright Statement.....	32

1. Camera Installation

1.1 Camera Introduction

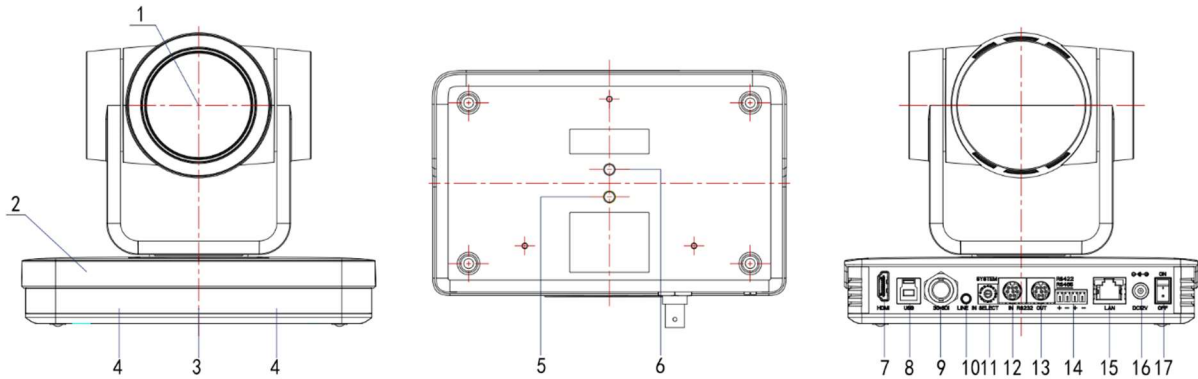

Figure 1.1 Interface of SU Model

- | | |
|---|--|
| <ul style="list-style-type: none"> 1. Camera Lens 2. Camera Base 3. Remote Control Receiving Indicator 4. Infrared Receiver 5. Tripod Screw Hole 6. Screw Hole for Tripod 7. HDM Output 8. USB3.0 Output 9. SDI Output | <ul style="list-style-type: none"> 10. Audio Input Interface (Line-in) 11. Rotary DIP Switch 12. RS232 Control Interface (input) 13. RS232 Control Interface (output) 14. RS422 Interface (Compatible with RS485) 15. Network Interface (LAN) 16. DC12V Input Power Supply Socket 17. Power Switch |
|---|--|

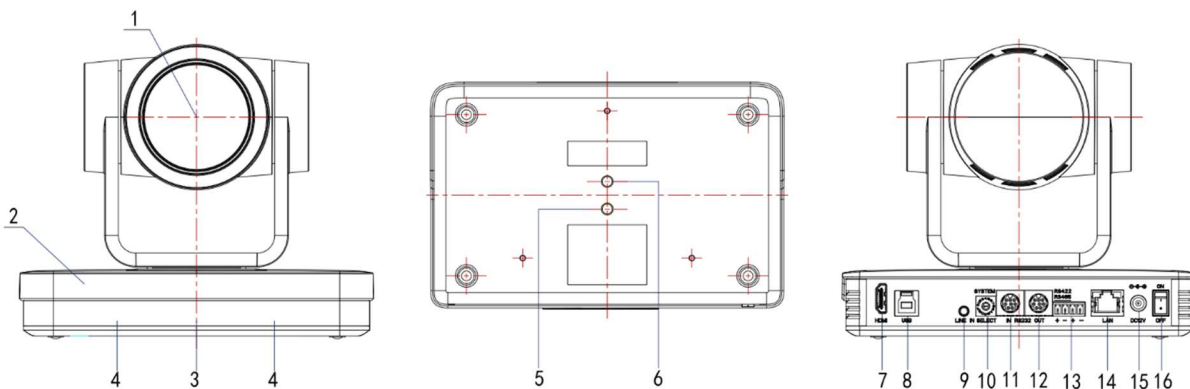

Figure 1.1 Interface of U3 Model

- | | |
|--|---|
| <ul style="list-style-type: none"> 1. Camera Lens 2. Camera Base 3. Remote Control Receiving Indicator 4. Infrared Receiver 5. Tripod Screw Hole 6. Screw Hole for Tripod 7. HDM Output 8. USB3.0 Output 9. Audio Input Interface (Line-in) | <ul style="list-style-type: none"> 10. Rotary DIP Switch 11. RS232 Control Interface (input) 12. RS232 Control Interface (output) 13. RS422 Interface (Compatible with RS485) 14. Network Interface (LAN) 15. DC12V Input Power Supply Socket 16. Power Switch |
|--|---|

1.2 Interfaces and Connection

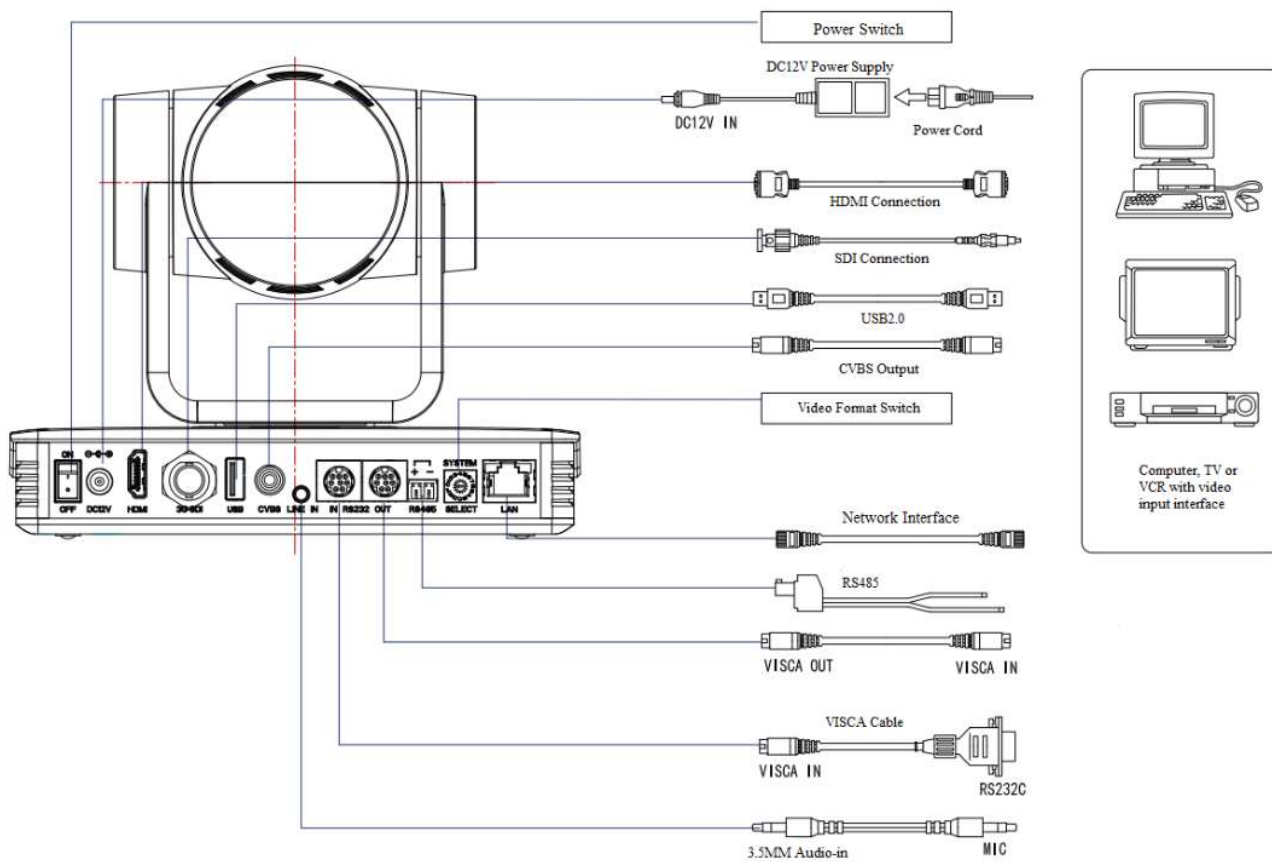

Figure 1.3 Wiring Diagram

- 1) After power on and self-warming, the camera will automatically return to the preset 0 position if it's pre-set.
 - 2) The default address for the IR remote control is 1#.
- If the menu restored to factory defaults, the remote control default address will restore to 1#.

1.3 Mounting Brackets

Notes:

Ceiling or wall mounting brackets can only be mounted on template and concrete wall.
For safety reason, plasterboard is not recommended.

1) Wall Mounting:

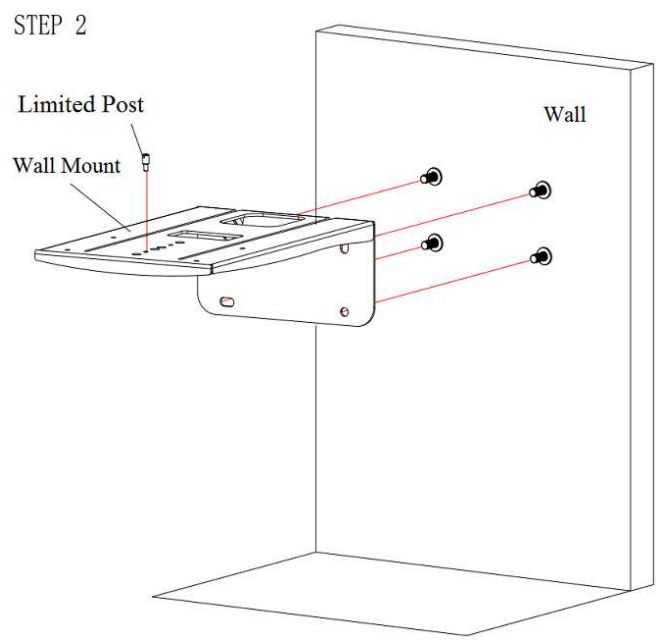
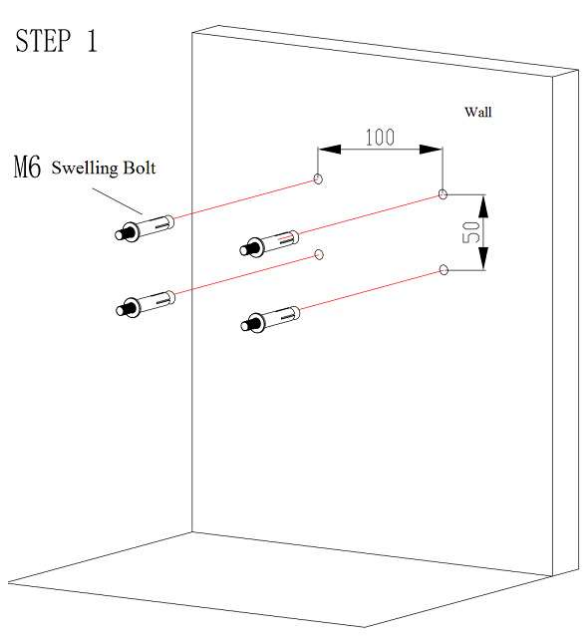
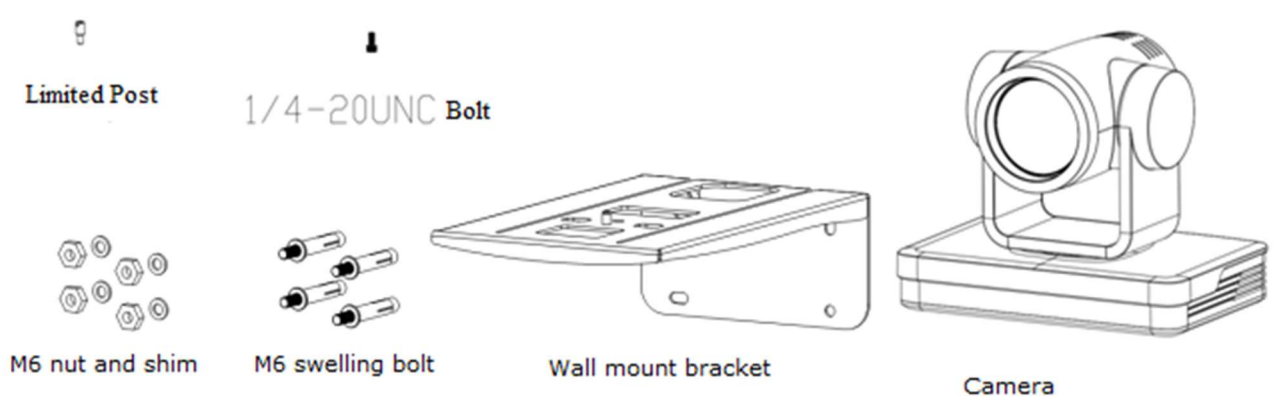

STEP 3

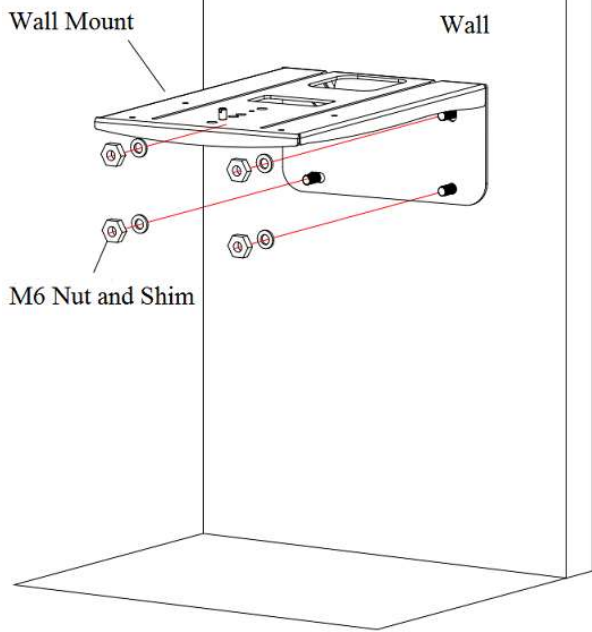

STEP 4

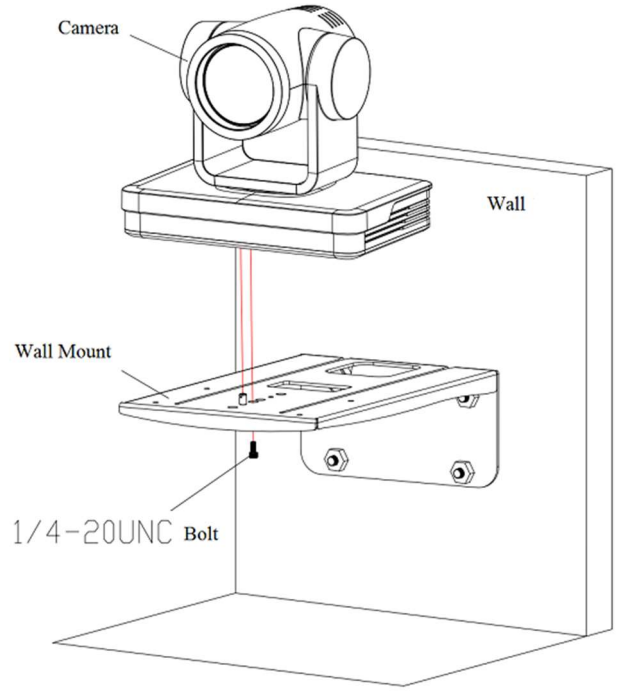

STEP 5

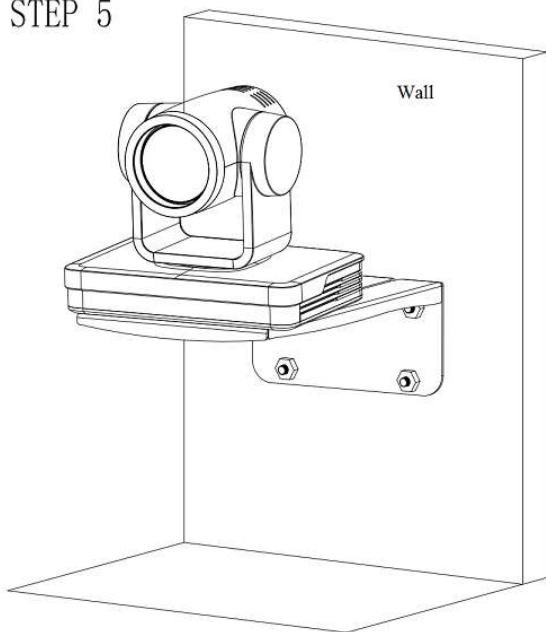

2) Ceiling Mounting

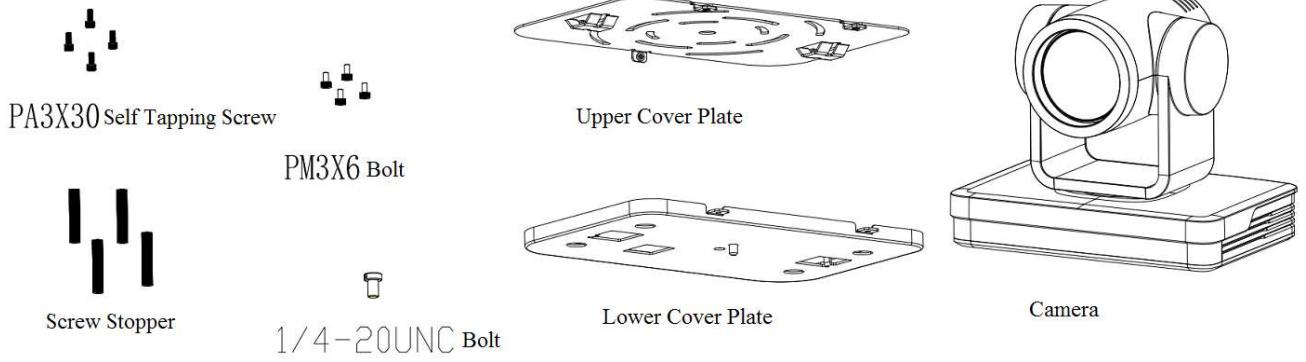

STEP 1

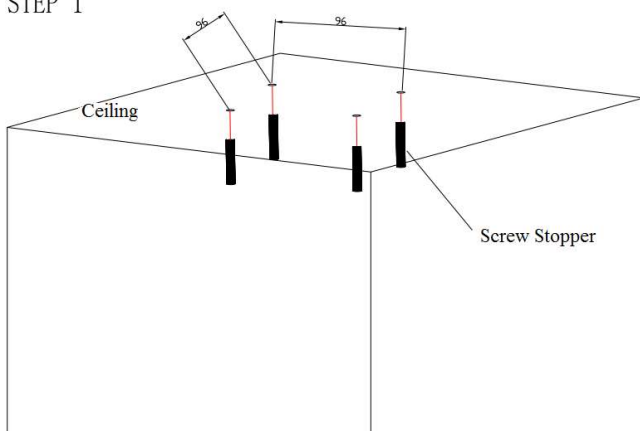

STEP 2

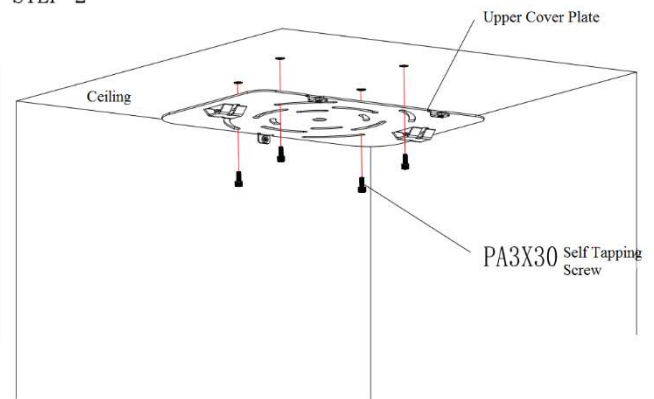

STEP 3

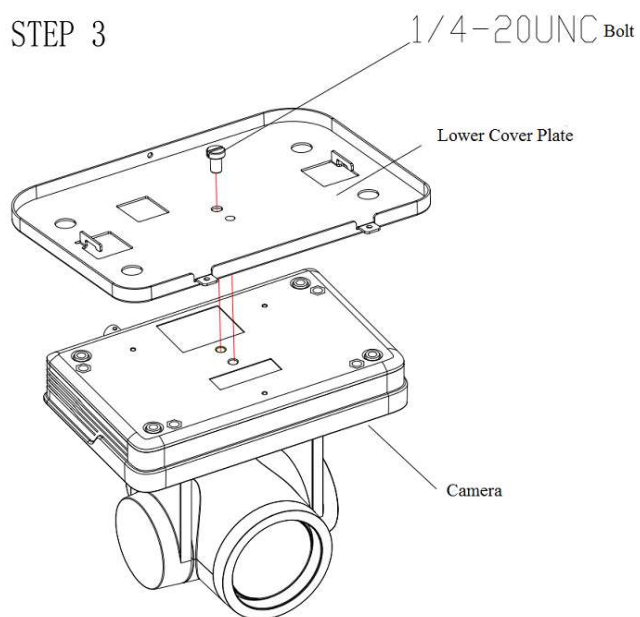

STEP 4

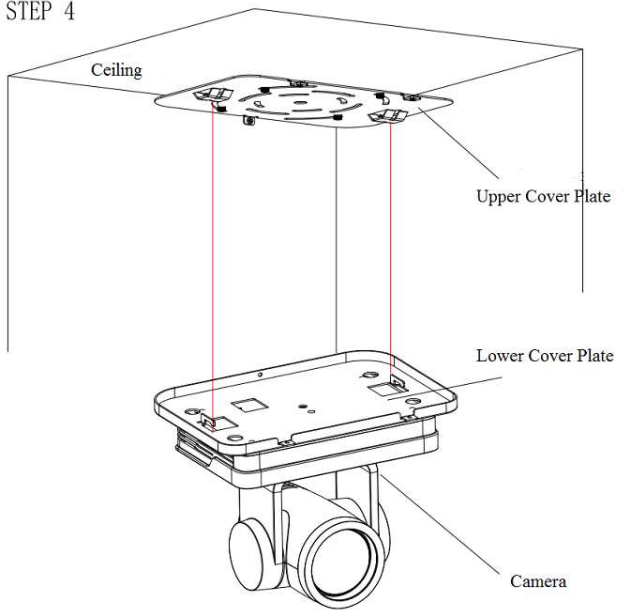

STEP 5

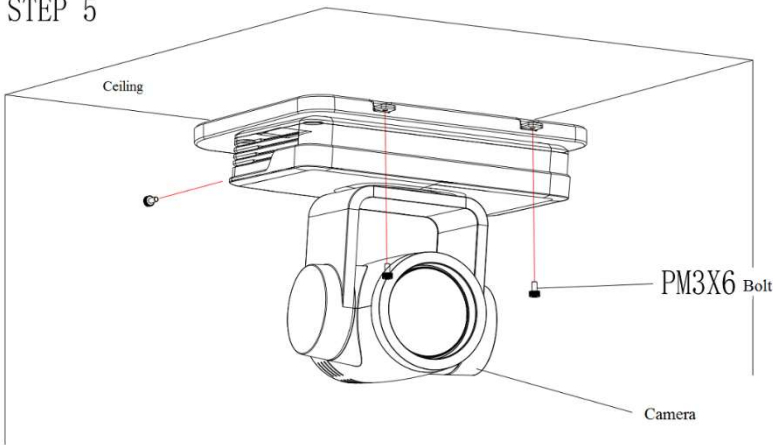

2. Product Overview

2.1 Model

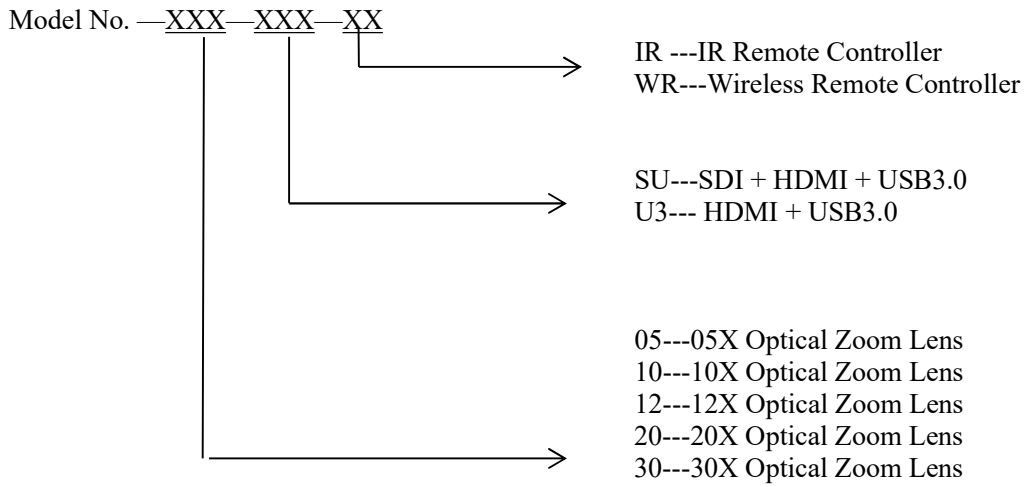

Figure 2.1 Product Model

2.2 Dimension

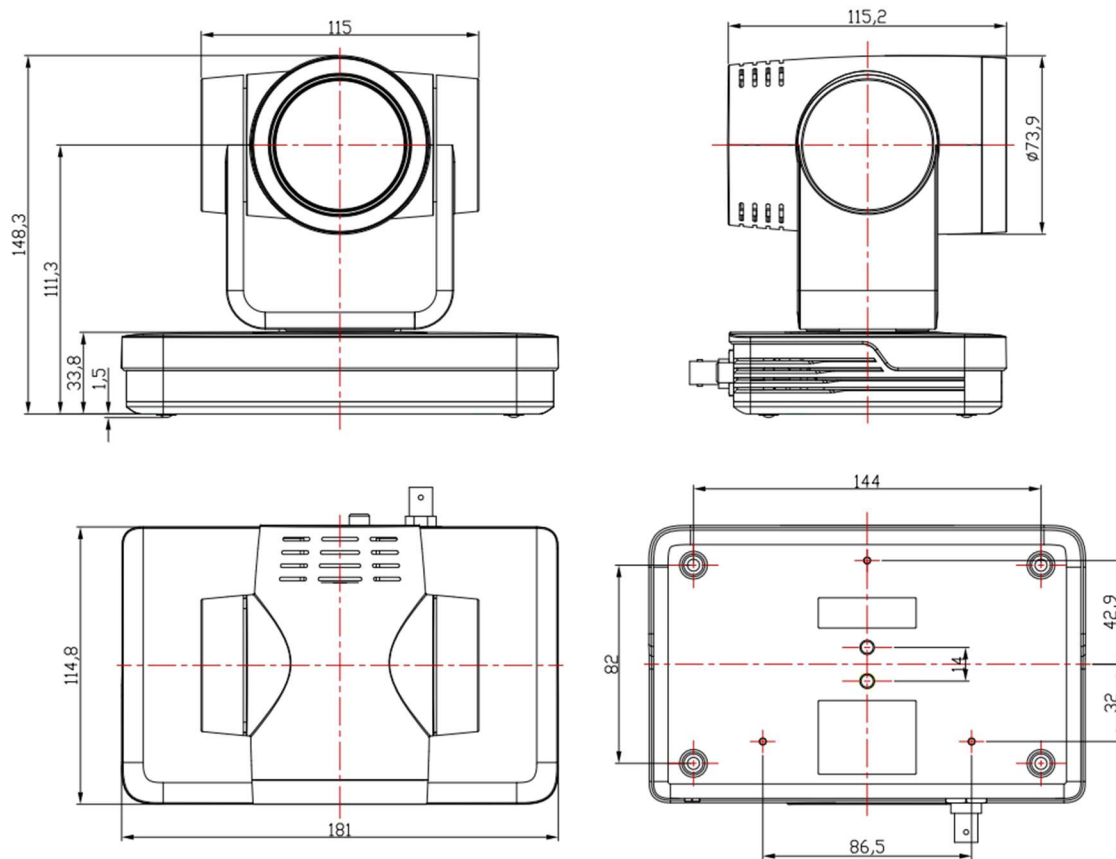

Figure 2.2 Product Dimension

2.3 Accessory

Please check below standard and optional accessories when unpacking the box.

Standard Accessory	Optional Accessory
Power adapter	Wireless Remote Control
IR Remote Control	Ceiling Mount
RS232 Cable	Wall Mount
User Manual	
USB3.0 Cable	

2.4 RS-232 Interface

1). RS-232 Interface Definition

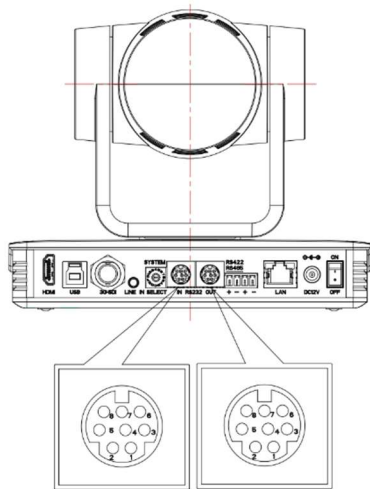

Connection to PC or Camera Controller

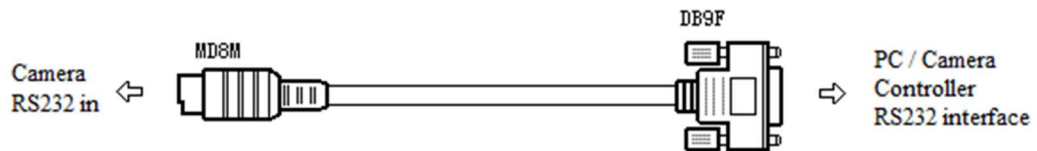
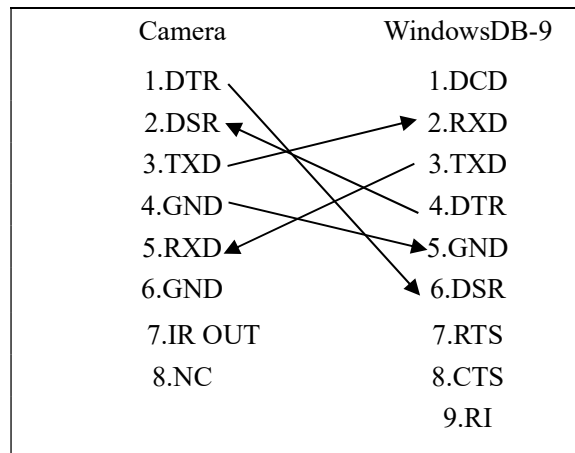

2). RS232 Mini-DIN 8-pin: Port Definition

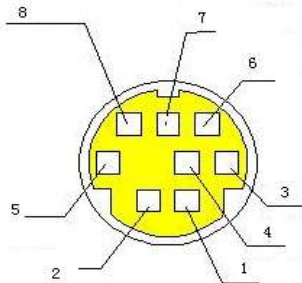

NO.	Port	Definition
1	DTR	Data Terminal Ready
2	DSR	Data Set Ready
3	TXD	Transmit Data
4	GND	Signal Ground
5	RXD	Receive Data
6	GND	Signal Ground
7	IR OUT	IR Commander Signal
8	NC	No Connection

3). RS232 (DB9) Port Definition

NO.	Port	Definition
1	DCD	Data Carrier Detect
2	RXD	Receive Data
3	TXD	Transmit Data
4	DTR	Data Terminal Ready
5	GND	System Ground

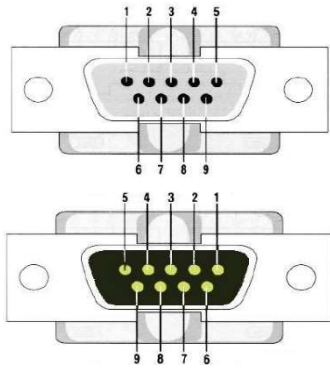

6	DSR	Data Set Ready
7	RTS	Request to Send
8	CTS	Clear to Send
9	RI	Ring Indicator

4). VISCA networking as shown below:

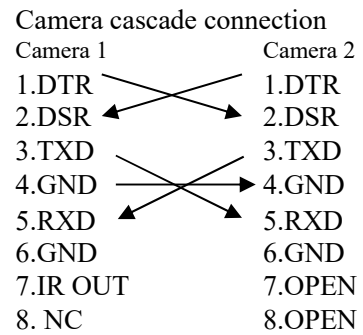
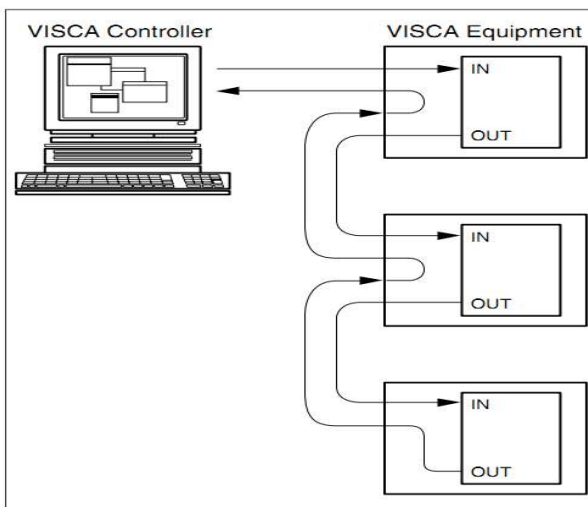

2.5 Rotary DIP Switch

Dial-up	video format	Dial-up	video format
0	1080P60	8	720P30
1	1080P50	9	720P25
2	1080I60	A	1080P59.94
3	1080I50	B	1080I59.94
4	720P60	C	720P59.94
5	720P50	D	1080P29.97
6	1080P30	E	720P29.97
7	1080P25	F	video format to be set on the menu

Note: 1. Please remember to reboot the camera to take effect when video format is switched.

2.If switch to F, please power off and reboot to take effect.

2.6 Main Features

This series camera has perfect functions, superior performance and rich video output interfaces; Featuring with advanced ISP processing algorithms, offering vivid and high resolution video with a strong sense of depth and fantastic color rendition. It supports H.264/H.265 encoding which makes motion video more fluent and clear under low bandwidth conditions.

- **Full HD Resolution:** 1/2.8 inch high quality CMOS sensor. Resolution is up to 1920x1080 with frame rate up to 60 fps.
- **Multiple Optical Zoom Lens:** 5X/10X/12X/20X/30X optical zoom lens. The 5X zoom camera is with 83.7° FOV without distortion.
- **Leading Auto Focus Technology:** Fast, accurate and stable auto focusing technology.
- **Low Noise and High SNR:** Super high SNR image is achieved with low noise CMOS. Advanced 2D/3D noise reduction technology further reduces the noise while ensuring high image clarity.
- **Multiple video output interfaces:** HDMI, SDI, USB3.0, LAN. Simultaneously output audio and video signal via HDMI, SDI, USB3.0 and LAN. LAN support POE power supply, USB3.0 support dual stream output, SDI output could up to 100M with 1080P@60fps.
- **Multiple Audio/Video Compression Standards:** Support H.264/H.265 video compression, up to 1920×1080 resolution 60 fps; support AAC, MP3 and G.711A audio compression, 8000,16000,32000,44100,48000 sampling frequency
- **Video / Audio Record and Store:** USB2.0 interface supports U disk storage, real-time record and store
- **Built-in Gravity Sensor:** Support PTZ auto-flip function and easy installation.
- **Multiple Network Protocol:** Support ONVIF, GB/T28181, RTSP, RTMP protocols; Support RTMP push mode, easy to be connected to streaming server (Wowza,FMS); Support RTP multicast mode; Support network full command VISCA control protocol.
- **Control Interface:** RS422 compatible with RS485, RS232-IN, RS2323-OUT, RS232 (cascade connection) .

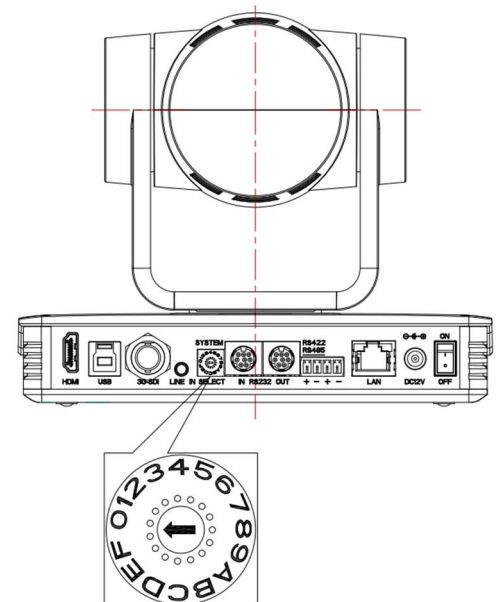

- **Multiple Control Protocol:** Support VISCA, PELCO-D, PELCO-P protocols; Support automatic identification protocols.
- **Quiet Pan / Tilt Movement:** With high accuracy step driving motor, camera can pan / tilt extremely quiet and smooth.
- **Auto sleep function:** Auto sleep/wake up function with low power consumption, less than 400mw.
- **Multiple presets:** Up to 255 presets (10 presets via remote control).
- **IR / Wireless Remote Control:** Users can choose IR remote control or wireless remote control according to different conditions. 2.4G wireless remote control is not affected by the angle, distance or infrared interference. Far-end-control is also available.
- **Multiple Application:** Online-education, Lecture Capture, Webcasting, Video conferencing, Tele-medicine, Unified Communication, Emergency command and control systems, etc.

2.7 Technical Parameter

Model	5X	10X	12X	20X	30X
Camera Parameter					
Optical Zoom	5X f=3.1-15.5mm	10X f=4.7-47mm	12X f=3.9-46.8mm	20X 5.2-98mm	30X f=4.3-129mm
Sensor	1/2.8 inch high quality HD CMOS sensor				
Effective Pixels	16: 9, 2.07 megapixel				
Video Format	HDMI/SDI video format 1080P60/50/30/25, 1080I60/50, 720P60/50 USB3.0 interface video format: Main Stream: YUY2/MJPEG/NV12/H.264/H.265: 1920×1080P30,1280×720P30,1024×576P30,960×540P30,800×448P30,720×480P30,640×360P30, 640×480P30,320×176P30 Sub Stream: YUY2/NV12: 640×360P30,640×480P30,320×176P30 MJPEG/H.264/H.265: 1920×1080P30,1280×720P30, 1024×576P30,960×540P30,800×448P30,720×480P30,640×360P30, 640×480P30,320×176P30				
View Angle	84°(W) 20°(T)	60.9°(W) 6.43°(T)	72.5°(W) 6.3°(T)	56° (W) 3.2°(T)	65°(W) 2.34°(T)
AV	F1.8 – F2.8	F1.6 – F3.0	F1.8 – F2.4	F1.5~ F3.0	F1.6 – F4.7
Digital Zoom	10X				
Minimum Illumination	0.5Lux (F1.8, AGC ON)				
DNR	2D & 3D DNR				
White Balance	Auto / Manual/ One Push/ Specify color temperature (range: 2400k-7100k)				
Focus/Aperture/ Electronic Shutter	Auto/Manual/One Push Focus				
Iris	Auto/Manual				
Shutter	Auto/Manual				
BLC	ON/OFF				
WDR	OFF/ Dynamic level adjustment				
Video Adjustment	Brightness, Color, Saturation, Contrast, Sharpness, B/W mode, Gamma curve				
SNR	>50dB				
Input/output Interface					

Video Interfaces	UV570-05/10/12/20/30-SU Model: HDMI, SDI, LAN(POE), USB3.0(type B compatible with USB2.0) , RS232-IN, RS232-OUT, RS422 (compatible with RS485), A-IN, Rotary DIP switch, DC 12V port, Power Switch UV570-05/10/12/20/30-U3 Model: HDMI, LAN(POE), USB3.0(type B compatible with USB2.0) , RS232-IN, RS232-OUT, RS422 (compatible with RS485), A-IN, Rotary DIP switch, DC 12V port, Power Switch
Video Output	HDMI, SDI, LAN, USB3.0, CVBS
Video Stream	Dual stream output
Video Compression Format	LAN Interface: H.265, H.264, Dual stream output USB3.0 Interface: YUY2, MJPEG, H.264, NV12, H.265
Audio Input Interface	Double track 3.5mm linear input
Audio Output Interface	HDMI, SDI, LAN, USB3.0
Audio Compression Format	AAC/MP3/G.711A
Control Interface	RS232-IN, RS232-OUT, RS422 (compatible with RS485)
Control Protocol	VISCA/Pelco-D/Pelco-P, Baud Rate: 115200/38400/9600/4800/2400bps
Power Interface	HEC3800 outlet (DC12V)
Input Voltage	DC12V±10%
Input Electric Current	Maximum: 1A
Power Consumption	Maximum: 12W
Network Protocols	RTSP, RTMP, ONVIF, GB/T28181; Network VISCA control protocol; Support remote upgrade, reboot and reset
USB Communication	UVC (Video), UAC (Audio)
PTZ Parameter	
Pan/Tilt Rotation	±170°, -30°~+90°
Pan Control Speed	0.1 - 100°/sec
Tilt Control Speed	0.1- 45°/sec
Preset Speed	Pan: 100°/sec, Tilt: 45°/sec
Preset Number	255 presets (10 presets via remote control)
Other Parameter	
Stored Temperature	-10°C~+70°C
Storage Humidity	20%~95%
Working Temperature	-10°C~+50°C
Working Humidity	20%~80%
Dimension	181mmX115mmX149mm
Weight	1.15KG
Accessory	
Package	Power Supply, RS232 Control Cable, USB3.0 cable(U3 model), IR Remote Control, User Manual
Optional Accessories	Ceiling / Wall Mount (Extra Cost)

3. Remote Control

3.1 Match Code for Wireless Remote Control



One to One Code Matching:

Press the "set" and "*" keys combined for 3 seconds, LED indicator starts flashing. Camera receive the signal and power on, LED indicator will go off if code matching successfully. The camera can be controlled by this wireless remote control only after one to one code pairing. Otherwise please clear the code matching of this remote control, or use other remote control to pair with the camera again.

If one to one code matching failed, the red LED light flashes for 20 seconds and then goes off, camera will stop code match and turn on sleep mode; Press any key to wake up the camera and re-match code.

Note: After code matching successfully, please select the camera address to control it.

Clear Code:

Press the "set" and "#" keys combined for 3 seconds, LED indicator starts flashing. Camera will power off and on, the LED indicator will go off if clear code successfully.

Sleep Mode and Wake Up:

Press any key to wake up the camera from sleep mode.

3.2 Keys Introduction for IR Remote Control

- 1). In this manual, "press the key" means a click rather than a long-press, and a special note will be given if a long-press for more than one second is required.
- 2). When a key-combination is required, do it in sequence. For example, "【*】+【#】+【F1】" means press "【*】" first and then press "【#】" and last press "【F1】".

1. Standby Key

The camera enters standby mode if long press 3s on standby key;

Long press 3s again on the standby key, the camera will self-check again and return to HOME position (If preset 0 position is set, the camera will return to preset 0 position).

2. Camera Selection



Select the camera address to control.

3. Focus Control

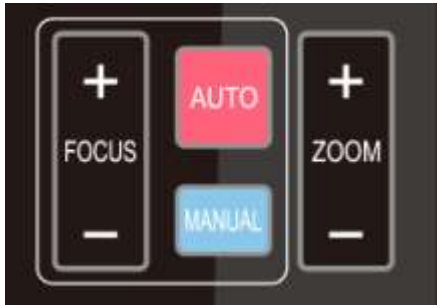

Auto: auto focus mode

Manual: manual focus mode

Focus + (near): Press **【FOCUS +】** key (Valid only in manual focus mode)

Focus - (far): Press **【FOCUS -】** key (Valid only in manual focus mode)

Press and hold the keys, the action of focus will keep continue and stop as soon as the key is released.

4. Zoom Control

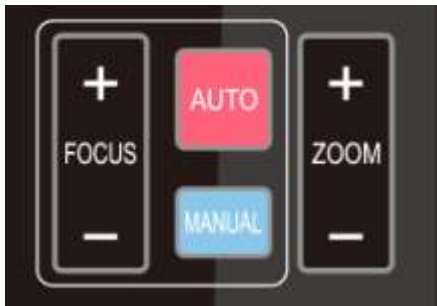

ZOOM +: press **【ZOOM +】** key to zoom in

ZOOM - : press **【ZOOM -】** key to zoom out

Press and hold the keys, the action of focus will keep continue and stop as soon as the key is released.

5. Set and Clear Presets



Set Preset: press **【SET PRESET】** button, and then press the number key 0-9 to set preset positions.

Note: 10 presets via remote control.

Call Preset: Press a number key 0-9 directly to call a preset position.

Clear Preset: press **【CLEAR PRESET】** button, and then press the number key 0-9 to clear preset positions.

Note : press the **【#】** key three times continually to clear all presets.

6. Pan/Tilt Control



Up: press ▲
 Down: press ▼
 Left: press ◀
 Right: press ▶
 Back to middle position: press“ 【HOME】 ”

Press and hold the up/down/left/right key, the pan/tilt movements will keep running, from slow to fast, until it runs to the endpoint; stop as soon as the key is released.

7. Menu Setting



【MENU】 : Open / close the OSD menu
 【HOME】 : Camera lens back to the middle position;
 Confirm button; Enter next menu
 【↑】 【↓】 : Choose item
 【←】 【→】 : Modify values
 【BLC ON/OFF】 : Turn on or off the back light compensation

8. Camera Remote Control Address Setting



【*】 + 【#】 + 【F1】 :Camera Address No.1
 【*】 + 【#】 + 【F2】 :Camera Address No. 2
 【*】 + 【#】 + 【F3】 :Camera Address No. 3
 【*】 + 【#】 + 【F4】 :Camera Address No. 4



9. Key Combination

- 1) **【#】 + 【#】 + 【#】** : Clear all presets
- 2) **【*】 + 【#】 + 【6】** : Restore factory defaults
- 3) **【*】 + 【#】 + 【3】** : Menu set to Chinese
- 4) **【*】 + 【#】 + 【4】** : Menu set to English
- 5) **【*】 + 【#】 + 【9】** : Flip switch
- 6) **【*】 + 【#】 + Auto**: Enter aging mode
- 7) **【#】 + 【*】 + Auto**: Exit aging mode
- 8) **【*】 + 【#】 + Manual**: Restore the default user name, password, and IP address
- 9) **【#】+【#】+【0】**: Switch the video format to 1080P60
- 10) **【#】+【#】+【1】**: Switch the video format to 1080P50
- 11) **【#】+【#】+【2】**: Switch the video format to 1080I60
- 12) **【#】+【#】+【3】**: Switch the video format to 1080I50
- 13) **【#】+【#】+【4】**: Switch the video format to 720P60
- 14) **【#】+【#】+【5】**: Switch the video format to 720P50
- 15) **【#】+【#】+【6】**: Switch the video format to 1080P30
- 16) **【#】+【#】+【7】**: Switch the video format to 1080P25
- 17) **【#】+【#】+【8】**: Switch the video format to 720P30
- 18) **【#】+【#】+【9】**: Switch the video format to 720P25

Note: If the address of former remote control is not address 1 but another one from 2, 3, 4, the corresponding camera address will restore to address 1 when all parameters are restored to factory default. User should change the remote control address to address 1.

3.3 Menu Introduction

Note: The modification valid only if exit the menu before save and power off.

1). Menu Control

【MENU】 : Enter / exit the OSD menu or return to the previous menu

【HOME】 : Enter next menu

【↑】 【↓】 : Choose item

【←】 【→】 : Modify values

2). English Menu

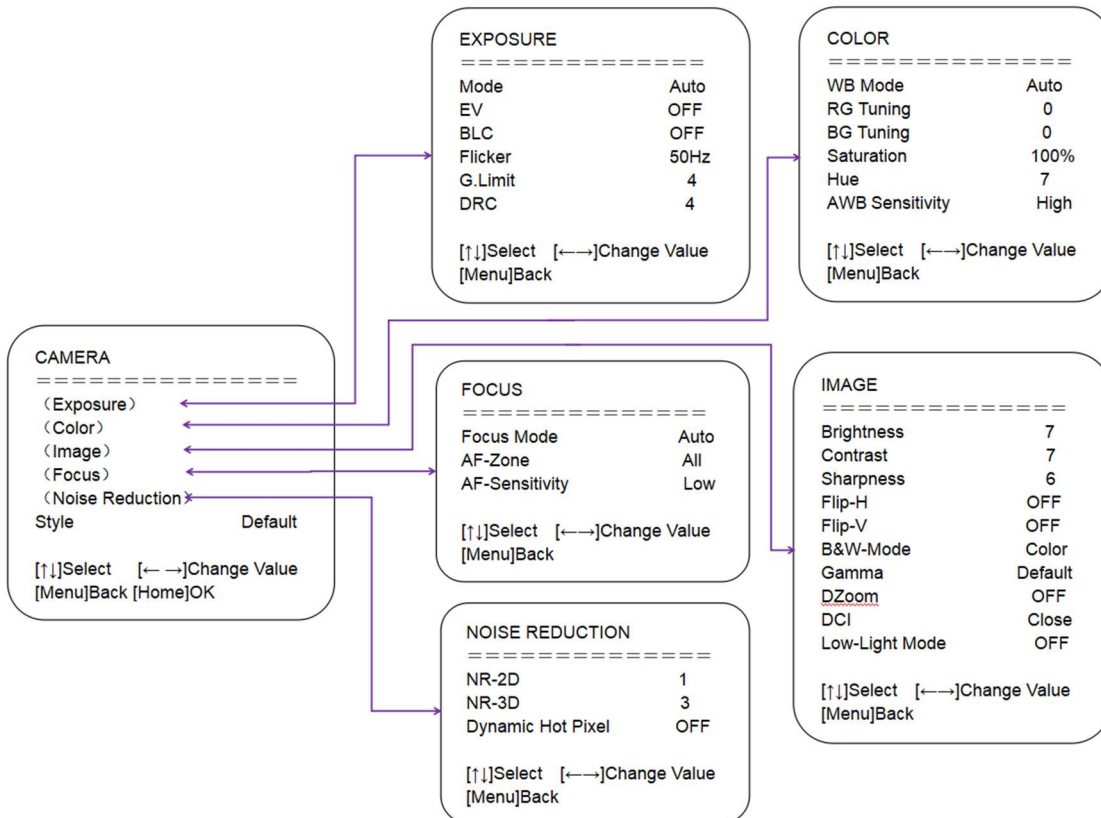
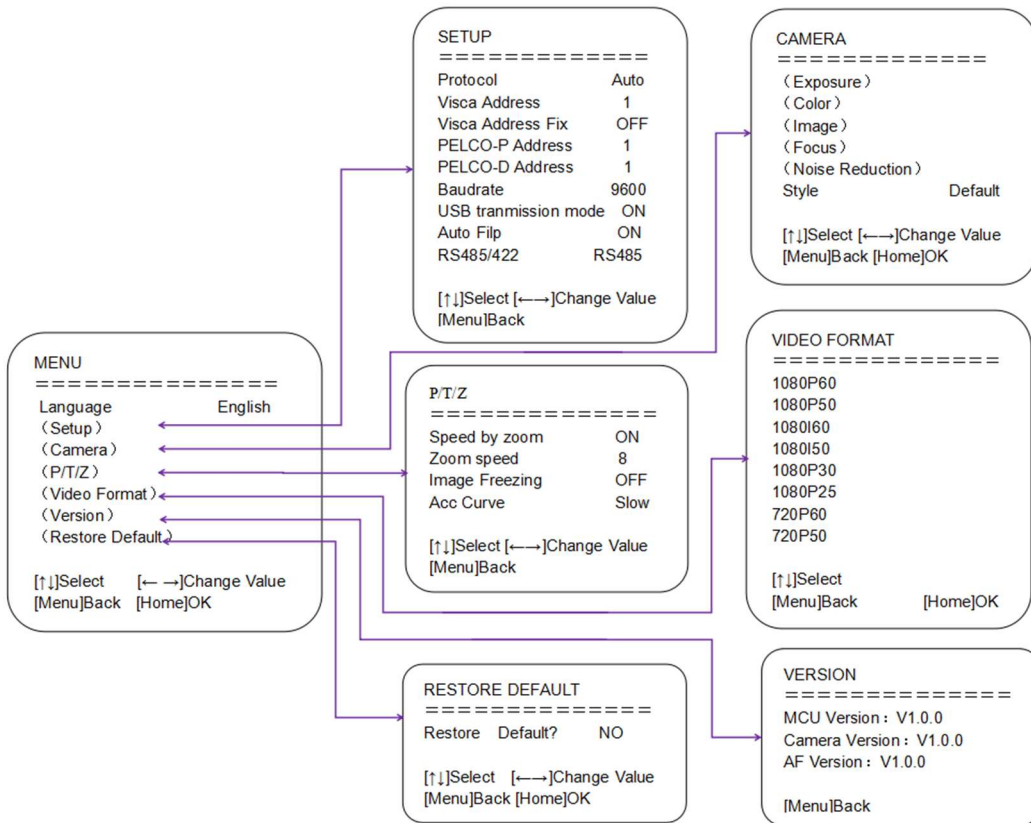

4. Network Configuration

4.1 Network Connection

Direct connection: Connect the camera and computer by network connecting cable.

Internet connection mode: Connect the camera to Internet by Router or Switcher and user can login the device by browser web page.

Note: Please do not put the power cable and network cable in places where can be easily touched, to prevent video unstable signal transmission due to poor contact of cables.

The computer must have the network segment where the camera IP address belongs to. The device will not be accessible if without the segment.

The camera default IP address is 192.168.5.163, segment 5 must be added in the computer.

Firstly open the window of Local Area Connection Properties on computer, select the “Internet protocol version 4(TCP/IPv4)”. Double click or click the property “Internet” protocol version 4 (TCP/IPv4) to enter into the Internet Protocol Version 4(TCP/IPv4) Properties window; select “Advanced” to enter into the Advanced TCP/IP Setting and add IP and subnet mask. Click the “Confirm” to finish the adding of IP segment. User can add the corresponding network segment according to the revised IP address of the camera.

Note: The IP address to be added cannot be same with that of other computers or devices. The existence of this IP address needs to be verified before adding.

To verify whether the network segment has been successfully added, click the “Start” and select “Operation” to input cmd, then click CONFIRM and open DOS command window, ping 192.168.5.26 and press Enter key to display information as shown below:

```
C:\Users\qq214>ping 192.168.5.26

Pinging 192.168.5.26 with 32 bytes of data:
Reply from 192.168.5.26: bytes=32 time<1ms TTL=128
Reply from 192.168.5.26: bytes=32 time=1ms TTL=128
Reply from 192.168.5.26: bytes=32 time<1ms TTL=128
Reply from 192.168.5.26: bytes=32 time<1ms TTL=128

Ping statistics for 192.168.5.26:
    Packets: Sent = 4, Received = 4, Lost = 0 (0% loss),
    Approximate round trip times in milli-seconds:
        Minimum = 0ms, Maximum = 1ms, Average = 0ms

C:\Users\qq214>
```

After camera power on and self-check, follow the steps above to verify network connection. Open DOS command window, ping 192.168.5.163 and press Enter key.

```
C:\Users\qq214>ping 192.168.5.163

Pinging 192.168.5.163 with 32 bytes of data:
Reply from 192.168.5.163: bytes=32 time=2ms TTL=64
Reply from 192.168.5.163: bytes=32 time=1ms TTL=64
Reply from 192.168.5.163: bytes=32 time<1ms TTL=64
Reply from 192.168.5.163: bytes=32 time=4ms TTL=64

Ping statistics for 192.168.5.163:
    Packets: Sent = 4, Received = 4, Lost = 0 (0% loss),
    Approximate round trip times in milli-seconds:
        Minimum = 0ms, Maximum = 4ms, Average = 1ms

C:\Users\qq214>_
```

4.2 IE Login

1) Web Page Login

Input the default IP address 192.168.5.163 in the browser and click Enter button to enter into Web Client login page. User can login as administrator and normal user. If login as administrator (Default User name/Password: admin), users can preview, playback, and set configuration in the Web Client; If login in as normal user (Default User name/Password:user1 or user2),users can only preview, playback and logout, no option for configuration.

Note: Web access support IE based browsers: IE, 360 browsers and etc.

Chrome login is available after firmware update, but only support basic configuration and preview video, no functions of record video, voice volume, video capture and playback.

3) Download and Install Plug in for IE login

If it's the first time to login via IE browser, the login page will prompt "Playback plug-in is not installed, please download and install!" Click on this message, download and install MRWebXinstall.exe according to the information.

Enter user name and password (default user name and password: "admin").

Users can manage and change user name, password and etc.

4.3 Streaming

1). Video Stream Capture

Configurations -> Video Configure-> Video Encode

Configurations

- Audio Configure
- Video Configure
 - Video Encode**
 - Stream Publish
 - RTP Multicast
 - Video Parameters
 - Video OSD
 - OSD Font Size
 - Video Out
- NetWork Configure
 - Network Port
 - Ethernet
 - DNS
- System Configure
 - SystAttr
 - SysTime
 - SysUser
 - Update
 - Default
 - Reboot

Video Encode

Stream	Main Stream	Sub Stream
Compressed Format	H.264	H.264
Profile	HP	HP
Image Size	1920*1080	320*180
Rate Control	CBR	CBR
Image Quality	Best	Better
Bit Rate(Kb/S)	4096	512
Frame Rate(F/S)	25	25
I Frame Interval	75	75
I Frame Min QP	20	20
Stream Name	live/av0	live/av1

Save

Configure the parameters according to the network environment.

Note: stream name live/av0 (live/ XXX)

For example:

The default IP address of the camera is 192.168.5.163. The way to obtain the RTSP video stream is as below

rtsp://192.168.5.163:554/live/av0 (av0 main stream)

rtsp://192.168.5.163:554/live/av1 (av1 sub stream)

The default IP address of the camera is 192.168.5.163. the way to obtain RTMP video stream is as below

rtmp://192.168.5.163:1935/live/av0 (av0 main stream)

rtmp://192.168.5.163:1935/live/av1 (av1 sub stream)

2). Push Video Stream

Configurations -> Video Configure-> Stream Publish

Configurations	Stream Publish		
	Stream	Main Stream	Sub Stream
<ul style="list-style-type: none"> Local Configure Audio Configure Video Configure <ul style="list-style-type: none"> Video Encode Stream Publish Video Parameters Video OSD OSD Font Size Video Out NetWork Configure <ul style="list-style-type: none"> Network Port Ethernet DNS GB28181 System Configure <ul style="list-style-type: none"> SystAttr SysTime SysUser Update Default Reboot 	<input type="checkbox"/>	<input type="checkbox"/>	
	Enable		
	Protol Type	<input type="text" value="RTMP"/>	<input type="text" value="RTMP"/>
	Host Address	<input type="text" value="192.168.5.11"/>	<input type="text" value="192.168.5.11"/>
	Host Port	<input type="text" value="1935"/>	<input type="text" value="1935"/>
	Stream Name	<input type="text" value="live/av0"/>	<input type="text" value="live/av1"/>
	User Name	<input type="text"/>	<input type="text" value="1"/>
	Password	<input type="text"/>	<input type="text"/>
	<input type="button" value="Save"/>		

Push RTMP stream to public network server, the stream camera must be on the public network, otherwise it will fail to connect to server.

Host address: server address, which can be either a domain name or an IP address

Host port: server default port number

Stream name: live/test (live/ XXX)

Username and password: the username and password set by the server, or leave it empty

Access url: rtmp://host domain name: host port/live/xxx

Or (rtmp://host IP address: host port/live/xxx)

4.4 Software Upgrading

1). Log in to the web page and manage camera settings. The default page is preview interface, where users can PTZ control, record video, preset camera positions and etc.

2). Configurations -> System Configure-> Update

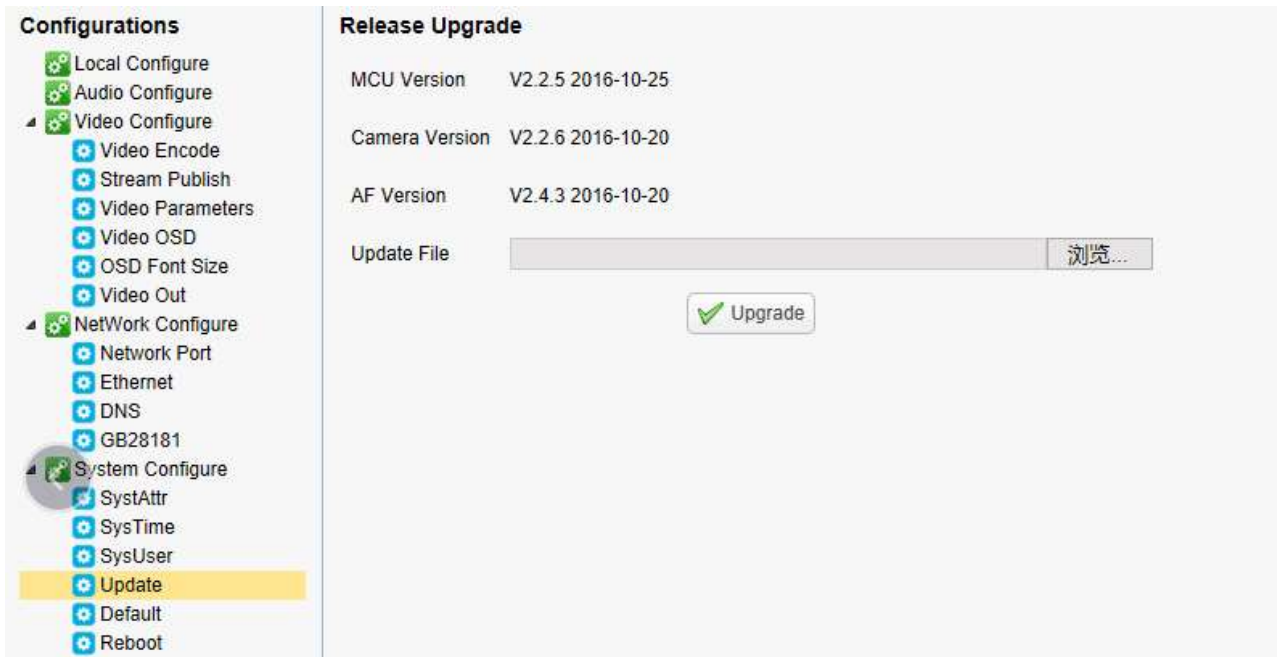

- 3). Click "browse" to select .mrg update file, then click upgrade button to finish software upgrading.
 - 4). Camera reboot after completion of firmware update. It prompts with "successful upgrade".
- Log in to check the firmware version to make sure software upgrade successful.
Then click "restore factory default", reboot and restore parameters to factory default (default IP 192.168.5.163, user name: admin; password admin).

5. Serial port communication and control

The camera could be controlled through RS232/RS485 interface; RS232C serial parameter are as follows:
Baud rate: 2400/4800/9600/115200 bits / sec; Start bit: 1; data bits: 8; Stop bit: 1; Parity: None.

5.1 VISCA Protocol Return Command

Ack/Completion Message		
	Command packet	Note
ACK	z0 41 FF	Returned when the command is accepted.
Completion	z0 51 FF	Returned when the command has been executed.

z = camera address + 8

Error Messages		
	Command packet	Note
Syntax Error	z0 60 02 FF	Returned when the command format is different or when a command with illegal command parameters is accepted
Command Not Executable	z0 61 41 FF	Returned when a command cannot be executed due to current conditions. For example, when commands controlling the focus manually are received during auto focus.

5.2 VISCA Protocol Control Command

Command	Function	Command packet	Note
AddressSet	Broadcast	88 30 0p FF	p: Address setting
IF_Clear	Broadcast	88 01 00 01 FF	I/F Clear
CommandCancel		8x 21 FF	
CAM_Power	On	8x 01 04 00 02 FF	Power ON/OFF
	Off	8x 01 04 00 03 FF	
CAM_Zoom	Stop	8x 01 04 07 00 FF	p = 0(low) - F(high) pqrs: Zoom Position
	Tele(Standard)	8x 01 04 07 02 FF	
	Wide(Standard)	8x 01 04 07 03 FF	
	Tele(Variable)	8x 01 04 07 2p FF	
	Wide(Variable)	8x 01 04 07 3p FF	
	Direct	8x 01 04 47 0p 0q 0r 0s FF	
CAM_Focus	Stop	8x 01 04 08 00 FF	p = 0(low) - F(high) pqrs: Focus Position
	Far(Standard)	8x 01 04 08 02 FF	
	Near(Standard)	8x 01 04 08 03 FF	
	Far(Variable)	8x 01 04 08 2p FF	
	Near (Variable)	8x 01 04 08 3p FF	
	Direct	8x 01 04 48 0p 0q 0r 0s FF	
	Auto Focus	8x 01 04 38 02 FF	
	Manual Focus	8x 01 04 38 03 FF	
	One Push mode	8x 01 04 38 04 FF	
CAM_Zoom Focus	Direct	8x 01 04 47 0p 0q 0r 0s 0t 0u 0v 0w FF	pqrs: Zoom Position tuvw: Focus Position
CAM_AFSensitivity	High	8x 01 04 58 01 FF	Focus sensitivity Setting
	Normal	8x 01 04 58 02 FF	
	Low	8x 01 04 58 03 FF	
CAM_AFZone	Top	8x 01 04 AA 00 FF	Focus Region Setting
	Center	8x 01 04 AA 01 FF	
	Bottom	8x 01 04 AA 02 FF	
	ALL	8x 01 04 AA 03 FF	
CAM_WB	One Push mode	8x 01 04 35 03 FF	One Push WB Trigger(Enabled during One Push WB mode) pq = 00--33 WBMode
	One Push Trigger	8x 01 04 10 05 FF	
	CAM_WB Mode	8x 01 04 35 pq FF	
CAM_AWBSensitivity	Low	8x 01 04 A9 00 FF	WB Sensitivity Setting
	Normal	8x 01 04 A9 01 FF	
	High	8x 01 04 A9 02 FF	
CAM_RGain	Reset	8x 01 04 03 00 FF	Manual Control of R Gain pq: R Gain
	Up	8x 01 04 03 02 FF	
	Down	8x 01 04 03 03 FF	
	Direct	8x 01 04 43 00 00 0p 0q FF	
CAM_Bgain	Reset	8x 01 04 04 00 FF	Manual Control of B Gain pq: B Gain
	Up	8x 01 04 04 02 FF	
	Down	8x 01 04 04 03 FF	
	Direct	8x 01 04 44 00 00 0p 0q FF	
CAM_AE	Full Auto	8x 01 04 39 00 FF	Automatic Exposure mode
	Manual	8x 01 04 39 03 FF	Manual Control mode
	Shutter priority	8x 01 04 39 0A FF	Shutter Priority Automatic Exposure mode

Command	Function	Command packet	Note
	Iris priority	8x 01 04 39 0B FF	Iris Priority Automatic Exposure mode
	Bright	8x 01 04 39 0D FF	Bright mode
CAM_Shutter	Reset	8x 01 04 0A 00 FF	Shutter Setting
	Up	8x 01 04 0A 02 FF	
	Down	8x 01 04 0A 03 FF	
	Direct	8x 01 04 4A 00 00 0p 0q FF	pq: Shutter Position
CAM_Iris	Reset	8x 01 04 0B 00 FF	Iris Setting
	Up	8x 01 04 0B 02 FF	
	Down	8x 01 04 0B 03 FF	
	Direct	8x 01 04 4B 00 00 0p 0q FF	pq: Iris Position
CAM_Gain Limit	Reset	8x 01 04 0C 00 FF	Gain Limit Setting
	Up	8x 01 04 0C 02 FF	
	Down	8x 01 04 0C 03 FF	
	Gain Limit	8x 01 04 2C 0p FF	p: Gain Positon
CAM_Bright	Reset	8x 01 04 0D 00 FF	Bright Setting
	Up	8x 01 04 0D 02 FF	
	Down	8x 01 04 0D 03 FF	
	Direct	8x 01 04 4D 00 00 0p 0q FF	pq: Bright Positon
CAM_ExpComp	On	8x 01 04 3E 02 FF	Exposure Compensation ON/OFF
	Off	8x 01 04 3E 03 FF	
	Reset	8x 01 04 0E 00 FF	Exposure Compensation Amount Setting
	Up	8x 01 04 0E 02 FF	
	Down	8x 01 04 0E 03 FF	
	Direct	8x 01 04 4E 00 00 0p 0q FF	pq: ExpComp Position
CAM_Back Light	On	8x 01 04 33 02 FF	Back Light Compensation
	Off	8x 01 04 33 03 FF	
CAM_WDRStrength	Reset	8x 01 04 21 00 FF	WDR Level Setting
	Up	8x 01 04 21 02 FF	
	Down	8x 01 04 21 03 FF	
	Direct	8x 01 04 51 00 00 00 0p FF	p: WDR Level Positon
CAM_NR	2D	8x 01 04 53 0p FF	P=0-7 0:OFF
	3D	8x 01 04 54 0p FF	P=0-8 0:OFF
CAM_Gamma		8x 01 04 5B 0p FF	p = 0 – 4 0: Default 1: 0.45 2: 0.50 3: 0.55 4: 0.63
CAM_Low-Light Mode	ON	8x 01 04 2D 01 FF	Low-Light Mode Setting
	OFF	8x 01 04 2D 00 FF	
CAM_Flicker	OFF	8x 01 04 23 00 FF	OFF
	50HZ	8x 01 04 23 01 FF	50HZ
	60HZ	8x 01 04 23 02 FF	60HZ
CAM_Aperture	Reset	8x 01 04 02 00 FF	Aperture Control
	Up	8x 01 04 02 02 FF	
	Down	8x 01 04 02 03 FF	
	Direct	8x 01 04 42 00 00 0p 0q FF	pq: Aperture Gain
CAM_Picture effect	B&W-Mode	8x 01 04 63 04 FF	Picture effect Setting
	OFF	8x 01 04 63 00 FF	
CAM_Memory	Reset	8x 01 04 3F 00 pq FF	pq: Memory Number(=0 to 254) Corresponds to 0 to 9 on the Remote Commander
	Set	8x 01 04 3F 01 pq FF	
	Recall	8x 01 04 3F 02 pq FF	
CAM_LR_Reverse	On	8x 01 04 61 02 FF	Image Flip Horizontal ON/OFF

Command	Function	Command packet	Note
	Off	8x 01 04 61 03 FF	
CAM_PictureFlip	On	8x 01 04 66 02 FF	Image Flip Vertical ON/OFF
	Off	8x 01 04 66 03 FF	
CAM_ColorSaturation	Direct	8x 01 04 49 00 00 00 0p FF	P=0-E 0:60% 1:70% 2:80% 3:90% 4:100% 5:110% 6:120% 7:130% 8:140% 9:150% 10:160% 11:160% 12:180% 13:190% 14:200%
CAM_IDWrite		8x 01 04 22 0p 0q 0r 0s FF	pqrs: Camera ID (=0000 to FFFF)
SYS_Menu	ON	8x 01 04 06 06 02 FF	Turn on the menu screen
	OFF	8x 01 04 06 06 03 FF	Turn off the menu screen
IR_Receive	ON	8x 01 06 08 02 FF	IR(remote commander)receive On/Off
	OFF	8x 01 06 08 03 FF	
IR_ReceiveReturn	On	8x 01 7D 01 03 00 00 FF	IR(remote commander)receive message via the VISCA communication ON/OFF
	Off	8x 01 7D 01 13 00 00 FF	
CAM_SettingReset	Reset	8x 01 04 A0 10 FF	Reset Factory Setting
CAM_Brightness	Direct	8x 01 04 A1 00 00 0p 0q FF	pq: Brightness Position
CAM_Contrast	Direct	8x 01 04 A2 00 00 0p 0q FF	pq: Contrast Position
CAM_Flip	OFF	8x 01 04 A4 00 FF	Single Command For Video Flip
	Flip-H	8x 01 04 A4 01 FF	
	Flip-V	8x 01 04 A4 02 FF	
	Flip-HV	8x 01 04 A4 03 FF	
CAM_VideoSystem	Set camera video system	8x 01 06 35 00 0p FF	P: 0~E Video format 0:1080P60 5:720P50 1:1080P50 6:1080P30 2:1080i60 7:1080P25 3:1080i50 8:720P30 4:720P60 9:720P25
Pan_tiltDrive	Up	8x 01 06 01 VV WW 03 01 FF	VV: Pan speed 0x01 (low speed) to 0x18 (high speed) WW: Tilt speed 0x01 (low speed) to 0x14 (high speed) YYYY: Pan Position ZZZZ: Tilt Position
	Down	8x 01 06 01 VV WW 03 02 FF	
	Left	8x 01 06 01 VV WW 01 03 FF	
	Right	8x 01 06 01 VV WW 02 03 FF	
	Upleft	8x 01 06 01 VV WW 01 01 FF	
	Upright	8x 01 06 01 VV WW 02 01 FF	
	DownLeft	8x 01 06 01 VV WW 01 02 FF	
	DownRight	8x 01 06 01 VV WW 02 02 FF	
	Stop	8x 01 06 01 VV WW 03 03 FF	
	AbsolutePosition	8x 01 06 02 VV WW 0Y 0Y 0Y 0Y 0Z 0Z 0Z 0Z FF	
	RelativePosition	8x 01 06 03 VV WW 0Y 0Y 0Y 0Y 0Z 0Z 0Z 0Z FF	
	Home	8x 01 06 04 FF	
Reset	8x 01 06 05 FF		
Pan-tilt LimitSet	Set	8x 01 06 07 00 0W 0Y 0Y 0Y 0Y 0Z 0Z 0Z 0Z FF	W:1 Up Right 0:Down Left YYYY: Pan Limit Position(TBD)
	Clear	8x 01 06 07 01 0W 07 0F 0F 0F 07 0F 0F 0F FF	ZZZZ: Tilt Limit Position(TBD)

5.3 VISCA Protocol Inquiry Command

Command	Command Packet	Return Packet	Note
CAM_PowerInq	8x 09 04 00 FF	y0 50 02 FF	On
		y0 50 03 FF	Off(Standby)
CAM_ZoomPosInq	8x 09 04 47 FF	y0 50 0p 0q 0r 0s FF	pqrs: Zoom Position
CAM_FocusAFModeInq	8x 09 04 38 FF	y0 50 02 FF	Auto Focus

		y0 50 03 FF	Manual Focus
		y0 50 04 FF	One Push mode
CAM_FocusPosInq	8x 09 04 48 FF	y0 50 0p 0q 0r 0s FF	pqrs: Focus Position
CAM_AFSensitivityInq	8x 09 04 58 FF	y0 50 01 FF	High
		y0 50 02 FF	Normal
		y0 50 03 FF	Low
CAM_AFZoneInq	8x 09 04 AA FF	y0 01 04 AA 00 FF	Top
		y0 01 04 AA 01 FF	Center
		y0 01 04 AA 02 FF	Bottom
		y0 01 04 AA 03 FF	All
CAM_WBModeInq	8x 09 04 35 FF	y0 50 pq FF	Auto
			pq =WBMode
CAM_AWBSensitivityInq	8x 09 04 A9 FF	y0 50 00 FF	Low
		y0 50 01 FF	Normal
		y0 50 02 FF	High
CAM_RGainInq	8x 09 04 43 FF	y0 50 0B FF	7000K
CAM_BGainInq	8x 09 04 44 FF	y0 50 00 00 0p 0q FF	pq: B Gain
CAM_AEModeInq	8x 09 04 39 FF	y0 50 00 FF	Full Auto
		y0 50 03 FF	Manual
		y0 50 0A FF	Shutter priority
		y0 50 0B FF	Iris priority
		y0 50 0D FF	Bright
CAM_ShutterPosInq	8x 09 04 4A FF	y0 50 00 00 0p 0q FF	pq: Shutter Position
CAM_IrisPosInq	8x 09 04 4B FF	y0 50 00 00 0p 0q FF	pq: Iris Position
CAM_Gain LimitInq	8x 09 04 2C FF	y0 50 0p FF	p: Gain Positon
CAM_BrightPosiInq	8x 09 04 4D FF	y0 50 00 00 0p 0q FF	pq: Bright Position
CAM_ExpCompModeInq	8x 09 04 3E FF	y0 50 02 FF	On
		y0 50 03 FF	Off
CAM_ExpCompPosInq	8x 09 04 4E FF	y0 50 00 00 0p 0q FF	pq: ExpComp Position
CAM_BacklightModeInq	8x 09 04 33 FF	y0 50 02 FF	On
		y0 50 03 FF	Off
CAM_WDRStrengthInq	8x 09 04 51 FF	y0 50 00 00 00 0p FF	p: WDR Strength
CAM_NRLevel(2D) Inq	8x 09 04 53 FF	y0 50 0p FF	P: 2DNRLLevel
CAM_NRLevel(3D) Inq	8x 09 04 54 FF	y0 50 0p FF	P:3D NRLevel
CAM_FlickerModeInq	8x 09 04 55 FF	y0 50 0p FF	p: Flicker Settings(0: OFF, 1: 50Hz, 2:60Hz)
CAM_ApertureInq	8x 09 04 42 FF	y0 50 00 00 0p 0q FF	pq: Aperture Gain
CAM_PictureEffectModeInq	8x 09 04 63 FF	y0 50 00 FF	Off
		y0 50 04 FF	B&W
CAM_MemoryInq	8x 09 04 3F FF	y0 50 0p FF	p: Memory number last operated.
SYS_MenuModeInq	8x 09 06 06 FF	y0 50 02 FF	On
		y0 50 03 FF	Off
CAM_LR_ReverseInq	8x 09 04 61 FF	y0 50 02 FF	On
		y0 50 03 FF	Off
CAM_PictureFlipInq	8x 09 04 66 FF	y0 50 02 FF	On

		y0 50 03 FF	Off
CAM_ColorSaturationInq	8x 09 04 49 FF	y0 50 00 00 00 0p FF	p: Color Gain setting 0h (60%) to Eh (130%)
CAM_IDInq	8x 09 04 22 FF	y0 50 0p FF	p: Gamma ID
IR_ReceiveInq	8x 09 06 08 FF	y0 50 02 FF	On
		y0 50 03 FF	Off
IR_ReceiveReturn		y0 07 7D 01 04 00 FF	Power ON/OFF
		y0 07 7D 01 04 07 FF	Zoom tele/wide
		y0 07 7D 01 04 38 FF	AF ON/OFF
		y0 07 7D 01 04 33 FF	Camera _Backlight
		y0 07 7D 01 04 3F FF	Camera _Memery
		y0 07 7D 01 06 01 FF	Pan_titleDriver
CAM_BrightnessInq	8x 09 04 A1 FF	y0 50 00 00 0p 0q FF	pq: Brightness Position
CAM_ContrastInq	8x 09 04 A2 FF	y0 50 00 00 0p 0q FF	pq: Contrast Position
CAM_FlipInq	8x 09 04 A4 FF	y0 50 00 FF	Off
		y0 50 01 FF	Flip-H
		y0 50 02 FF	Flip-V
		y0 50 03 FF	Flip-HV
CAM_GammaInq	8x 09 04 5B FF	y0 50 0p FF	p: Gamma setting
CAM_Low-LightModeInq	8x 09 04 2D FF	y0 50 00 FF	OFF
		y0 50 01 FF	ON
CAM_VersionInq	8x 09 00 02 FF	y0 50 ab cd mn pq rs tu vw FF	ab cd : vender ID (0220) mn pq : model ID rs tu : ARM Version vw : reserve
VideoSystemInq	8x 09 06 23 FF	y0 50 0p FF	P: 0~E Video format 0:1080P60 5:720P50 1:1080P50 6:1080P30 2:1080i60 7:1080P25 3:1080i50 8:720P30 4:720P60 9:720P25
Pan-tiltMaxSpeedInq	8x 09 06 11 FF	y0 50 ww zz FF	ww: Pan Max Speed zz: Tilt Max Speed
Pan-tiltPosInq	8x 09 06 12 FF	y0 50 0w 0w 0w 0w 0z 0z 0z 0z FF	www: Pan Position zzzz: Tilt Position

Note:[X] in the above table indicates the camera address to be operated, **【y】** = **【x + 8】** .

5.4 Pelco-D protocol command list

Function	Byte1	Byte2	Byte3	Byte4	Byte5	Byte6	Byte7
Up	0xFF	Address	0x00	0x08	Pan Speed	Tilt Speed	SUM
Down	0xFF	Address	0x00	0x10	Pan Speed	Tilt Speed	SUM
Left	0xFF	Address	0x00	0x04	Pan Speed	Tilt Speed	SUM
Right	0xFF	Address	0x00	0x02	Pan Speed	Tilt Speed	SUM
Upleft	0xFF	Address	0x00	0x0C	Pan Speed	Tilt Speed	SUM

Upright	0xFF	Address	0x00	0x0A	Pan Speed	Tilt Speed	SUM
DownLeft	0xFF	Address	0x00	0x14	Pan Speed	Tilt Speed	SUM
DownRight	0xFF	Address	0x00	0x12	Pan Speed	Tilt Speed	SUM
Zoom In	0xFF	Address	0x00	0x20	0x00	0x00	SUM
Zoom Out	0xFF	Address	0x00	0x40	0x00	0x00	SUM
Focus Far	0xFF	Address	0x00	0x80	0x00	0x00	SUM
Focus Near	0xFF	Address	0x01	0x00	0x00	0x00	SUM
Stop	0xFF	Address	0x00	0x00	0x00	0x00	SUM
Set Preset	0xFF	Address	0x00	0x03	0x00	Preset ID	SUM
Clear Preset	0xFF	Address	0x00	0x05	0x00	Preset ID	SUM
Call Preset	0xFF	Address	0x00	0x07	0x00	Preset ID	SUM
Query Pan Position	0xFF	Address	0x00	0x51	0x00	0x00	SUM
Query Pan Position Response	0xFF	Address	0x00	0x59	Value High Byte	Value Low Byte	SUM
Query Tilt Position	0xFF	Address	0x00	0x53	0x00	0x00	SUM
Query Tilt Position Response	0xFF	Address	0x00	0x5B	Value High Byte	Value Low Byte	SUM
Query Zoom Position	0xFF	Address	0x00	0x55	0x00	0x00	SUM
Query Zoom Position Response	0xFF	Address	0x00	0x5D	Value High Byte	Value Low Byte	SUM

5.5 Pelco-P protocol command list

Function	Byte1	Byte2	Byte3	Byte4	Byte5	Byte6	Byte7	Byte 8
Up	0xA0	Address	0x00	0x08	Pan Speed	Tilt Speed	0xAF	XOR
Down	0xA0	Address	0x00	0x10	Pan Speed	Tilt Speed	0xAF	XOR
Left	0xA0	Address	0x00	0x04	Pan Speed	Tilt Speed	0xAF	XOR
Right	0xA0	Address	0x00	0x02	Pan Speed	Tilt Speed	0xAF	XOR
Upleft	0xA0	Address	0x00	0x0C	Pan Speed	Tilt Speed	0xAF	XOR
Upright	0xA0	Address	0x00	0x0A	Pan Speed	Tilt Speed	0xAF	XOR
DownLeft	0xA0	Address	0x00	0x14	Pan Speed	Tilt Speed	0xAF	XOR
DownRight	0xA0	Address	0x00	0x12	Pan Speed	Tilt Speed	0xAF	XOR
Zoom In	0xA0	Address	0x00	0x20	0x00	0x00	0xAF	XOR
Zoom Out	0xA0	Address	0x00	0x40	0x00	0x00	0xAF	XOR
Stop	0xA0	Address	0x00	0x00	0x00	0x00	0xAF	XOR
Focus Far	0xA0	Address	0x01	0x00	0x00	0x00	0xAF	XOR
Focus Near	0xA0	Address	0x02	0x00	0x00	0x00	0xAF	XOR
Set Preset	0xA0	Address	0x00	0x03	0x00	Preset ID	0xAF	XOR
Clear Preset	0xA0	Address	0x00	0x05	0x00	Preset ID	0xAF	XOR
Call Preset	0xA0	Address	0x00	0x07	0x00	Preset ID	0xAF	XOR
Query Pan Position	0xA0	Address	0x00	0x51	0x00	0x00	0xAF	XOR
Query Pan Position Response	0xA0	Address	0x00	0x59	Value High Byte	Value Low Byte	0xAF	XOR
Query Tilt Position	0xA0	Address	0x00	0x53	0x00	0x00	0xAF	XOR
Query Tilt Position Response	0xA0	Address	0x00	0x5B	Value High Byte	Value Low Byte	0xAF	XOR
Query Zoom Position	0xA0	Address	0x00	0x55	0x00	0x00	0xAF	XOR
Query Zoom Position Response	0xA0	Address	0x00	0x5D	Value High Byte	Value Low Byte	0xAF	XOR

6. Maintenance and Troubleshooting

6.1 Maintenance

- 1) Please power off the camera and disconnect the power adapter and socket, if it's not used for a long run.
- 2) Use soft cloth or tissue to clean the camera cover.
- 3) Wipe it with a soft, dry cloth when cleaning the camera lens. Wipe it gently with a mild detergent if needed. Do not use strong or corrosive detergents to avoid scratching the lens and affecting the video quality.

6.2 Troubleshooting

1) No video output

- a. Check whether the camera power supply is connected, the voltage is normal, the power indicator is lit.
- b. Whether the machine could do self-check after restarted.
- c. Check whether the bottom of the DIP switch is the normal operating mode (see Table 2.2 and Table 2.3)
- d. Check whether the video output cable or video display is normal

2) No image sometimes

- a. Check whether the video output cable or video display is normal

3) Video dithering when zoom-in or zoom-out

- a. Check whether the camera installation position is solid
- b. Whether there is shaking machine or objects around the camera

4) Remote control not works

- a. Remote control address is set to 1 (if the machine is set back to the factory defaults, remote control addresses need to be back to 1 too)
- b. Check whether the battery is installed on the remote controller or low .
- c. Check the camera working mode is the normal operating mode (see Table 2.2 and Table 2.3)
- d. Check the menu whether is closed, camera control through remote controller is only available after exiting the menu. If video output from LAN, menu will not be displayed, menu will automatically exists 30s later, and then it can be controlled by remote controller.

5) Serial port not works

- a. Check whether the camera serial device protocol, baud rate, address is consistent
- b. Check whether the control cable is connected properly
- c. Check whether the camera working mode is the normal operating mode

6) Web pages cannot log in

- a. Check if the camera outputs video normally by connecting directly to the screen.
- b. Check whether the network cable is connected properly (Ethernet port yellow light flashes to indicate normal network cable connection)
- c. Check whether your computer is added the segment and the segment is consistent with the IP address of the

camera

d. Click "Start" and select "Run" and then type "cmd" in the computer; Click "OK" then turn on a DOS command window to enter ping 192.168.5.163. Press the Enter key to appear message as follows: Description network connection is normal

```
C:\Users\qq214>ping 192.168.5.163

Pinging 192.168.5.163 with 32 bytes of data:
Reply from 192.168.5.163: bytes=32 time=2ms TTL=64
Reply from 192.168.5.163: bytes=32 time=1ms TTL=64
Reply from 192.168.5.163: bytes=32 time<1ms TTL=64
Reply from 192.168.5.163: bytes=32 time=4ms TTL=64

Ping statistics for 192.168.5.163:
    Packets: Sent = 4, Received = 4, Lost = 0 (0% loss),
    Approximate round trip times in milli-seconds:
        Minimum = 0ms, Maximum = 4ms, Average = 1ms

C:\Users\qq214>_
```

7. Copyright Statement

All the contents in this manual and its copyright are owned by the company. No one is allowed to imitate, copy, or translate this manual without the company's permission. This manual contains no guarantee, standpoint expression or other implies in any form. Product specification and information in this manual is for reference only and subject to change without notice. All rights reserved. No reproducing is allowed without acknowledgement.